

**Application**

Series D31 hydraulic directional control valves are high performance, solenoid controlled, pilot operated, 2-stage, 4-way valves. They are available in 2 or 3-position styles and are manifold mounted. These valves conform to NFPA's D05H, CETOP 5 and can also be manufactured to an NFPA D05HE, CETOP 5H configuration.

**Operation**

Series D31 directional valves consist of a 5-chamber style main body, a case hardened sliding spool, and a pilot valve or pilot operators (hydraulic or pneumatic).

**Features**

- Easy access mounting bolts.
- 345 Bar (5000 PSI) pressure rating.
- Flows to 175 LPM (45 GPM) depending on spool.
- Choice of four operator styles.
- Rugged four land spools.
- Low pressure drop.
- Phosphate finish.
- Both NFPA and CETOP mounting styles available.

**A**

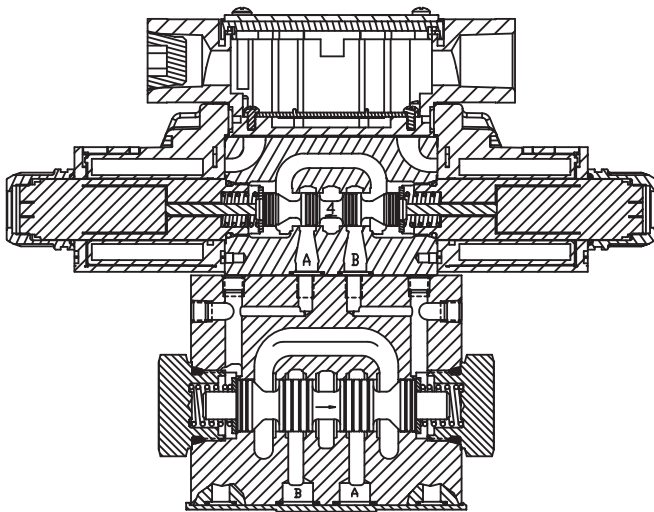

**D31\*W Solenoid Operated Plug-In Conduit Box**

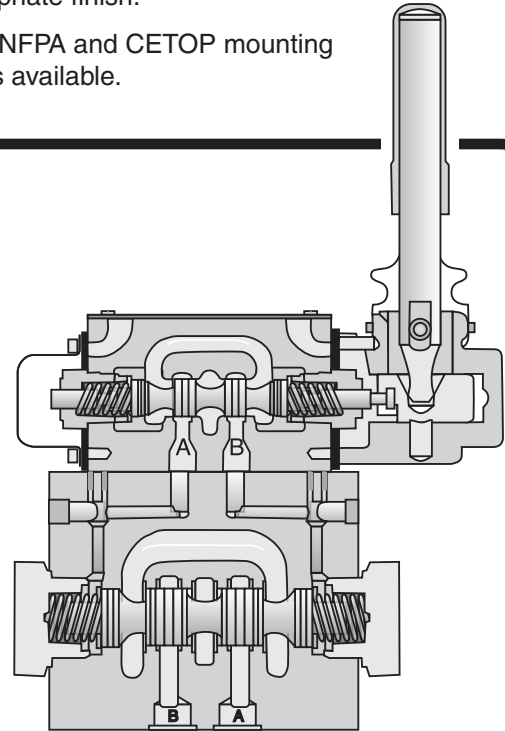

**D31\*L Lever Operated**

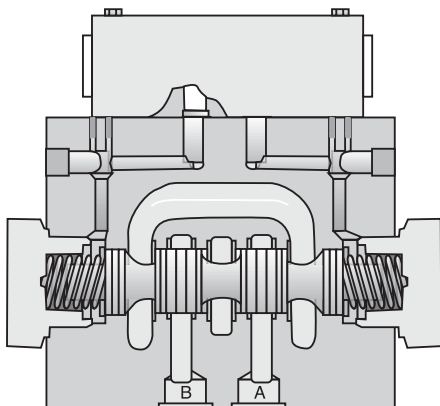

**D3\*P Oil Pilot Operated**

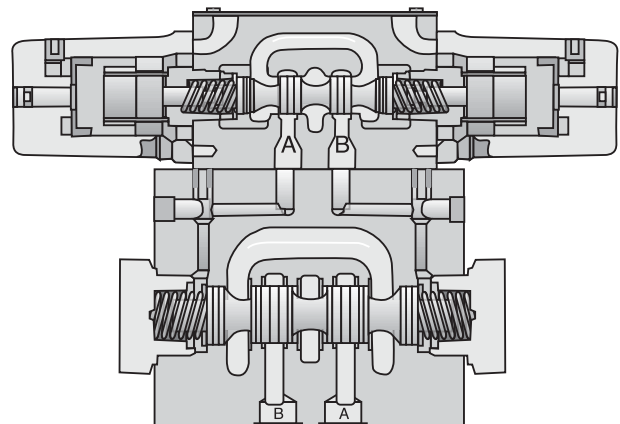

**D31\*A Air Pilot Operated**

**A**





**General Description**

Series D31 directional control valves are 5-chamber, pilot operated, solenoid controlled valves. The valves are suitable for manifold or subplate mounting.

**Features**

- **World design** – Available worldwide.
- **Mounting bolts below center line of spool** – Minimizes spool binding.
- **Five chamber style** – Eliminates pressure spikes in tubes, increasing valve life.
- **High pressure and flow ratings** – Increased performance options in a compact valve.

**Specifications**

<b>Mounting Pattern</b>	NFPA D05H, CETOP 5 NFPA D05HE, CETOP 5H
<b>Max. Operating Pressure</b>	345 Bar (5000 PSI) Standard 207 Bar (3000 PSI) 10 Watt CSA  207 Bar (3000 PSI)
<b>Max. Tank Line Pressure</b>	Internal Drain Model: 103 Bar (1500 PSI) AC Std. 207 Bar (3000 PSI) DC Std./AC Opt. External Drain Model: 207 Bar (3000 PSI) CSA  103 Bar (1500 PSI)
<b>Max. Drain Pressure</b>	103 Bar (1500 PSI) AC only 207 Bar (3000 PSI) DC Std./AC Opt. CSA  103 Bar (1500 PSI)
<b>Min. Pilot Pressure</b>	6.9 Bar (100 PSI)
<b>Max. Pilot Pressure</b>	345 Bar (5000 PSI) Standard CSA  207 Bar (3000 PSI)
<b>Nominal Flow</b>	76 Liters/Min (20 GPM)
<b>Maximum Flow</b>	See Switching Limit Charts

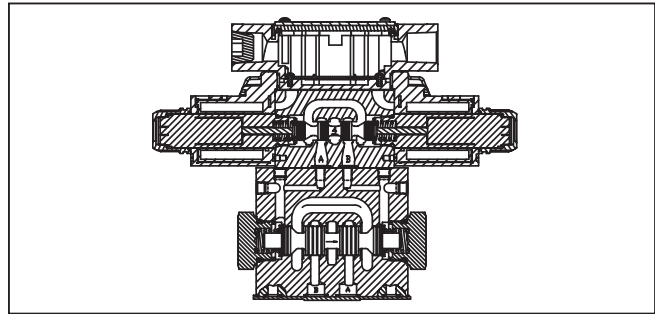
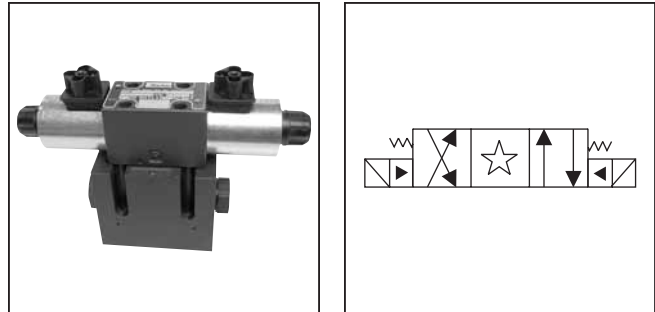

**Response Time**

Response time (milliseconds)  
 at 345 Bar (5000 PSI) is 76 LPM (20 GPM)

Solenoid Type	Pilot Pressure	Pull-In	Drop-Out
DC	500	40	50
	1000	36	50
	2000	34	50
AC	500	20	33
	1000	18	33
	2000	13	33

**Switching Limit Charts**

For Styles B, C, E, H and K

**D Style – external drain only (For internal drain see note below)**

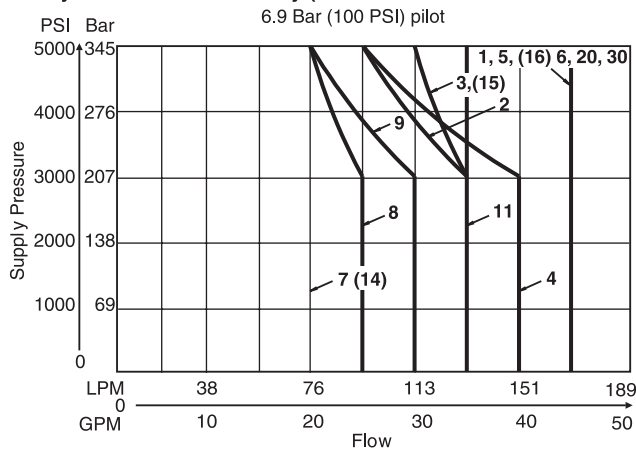

Note: Internal Drain  
 1, 4 spools – 113 LPM (30 GPM) max., 7 spool – per curve  
 All others – 95 LPM (25 GPM) max.

For Styles F and M – external drain only  
 (For internal drain see note below)

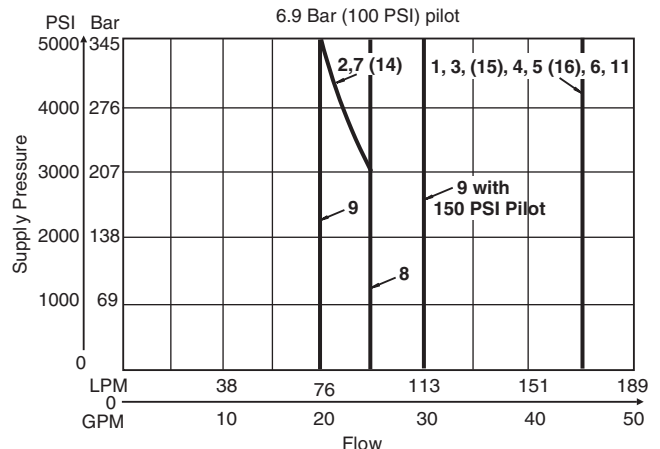

Note: Internal Drain  
 1, 4 spools – 113 LPM (30 GPM) max., 2, 9 & 14 spools – per curve  
 All others – 95 LPM (25 GPM) max.

**A**

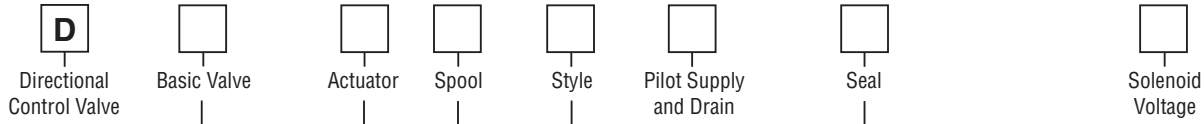

Code	Description
31D	NFPA D05HE, CETOP 5H, DIN NG10, D03 Pilot, ISO Port
31V	NFPA D05H, CETOP 5, D03 Pilot, NFPA Port

Code	Description
W#	Solenoid, Wet Pin, Screw-in
HW#	Reversed Wiring

Code	Description
N	Nitrile
V	Fluorocarbon

Code	Description
1*	Internal Pilot, External Drain
2*	External Pilot, External Drain
4#	Internal Pilot, Internal Drain
5	External Pilot, Internal Drain

Code	Description
A**	24/50 VAC
D	120 VDC
G	198 VDC
J	<b>24 VDC</b>
K	<b>12 VDC</b>
N***	220/50 VAC
P***	110/50 VAC
Q**	100/60 VAC
QD†	100 VAC/60 Hz 100 VAC/50 Hz
R	24/60 VAC
T	<b>240/60 - 220/50 VAC</b>
U	98 VDC
Y	<b>120/60 - 110/50 VAC</b>
Z	250 VDC

# Valve schematic symbols are per NFPA/ANSI standards, providing flow P to A when energizing solenoid A. Note operators reverse sides for #008 and #009 spools. See installation information for details. To configure per DIN standards (A coil over A port, B coil over B port) code valves as D31VHW\*\*\*.

\* F and M style available only with external drain.

# Not available with 002, 007, 008, 009 or 014 spools.

\*\* High watt only.

\*\*\* Explosion proof only.

† Available in DIN only.

Code	Symbol	Code	Symbol
001		011	
002		012	
003		014	
004		015	
005		016	
006		020*	
007		030**	
008*		081	
009**		082	
010			

Code	Description	Symbol
B*	Single solenoid, 2 position, spring offset. P to A and B to T in offset position.	
C	Double solenoid, 3 position, spring centered.	
D*	Double solenoid, 2 position, detent.	
E	Single solenoid, 2 position, spring centered. P to B and A to T when energized.	
F†	Single solenoid, 2 position, spring offset, energized to center. Spacer on A side. P to A and B to T in offset position.	
H*	Single solenoid, 2 position, spring offset. P to B and A to T in offset position.	
K	Single solenoid, 2 position, spring centered. P to A and B to T when energized.	
M†	Single solenoid, 2 position, spring offset, energized to center. Spacer on B side. P to B and A to T in offset position.	

\* 020 and 030 spools only.

† High watt only.

\* 008 & 020 spools have closed crossover.

\*\* 009 & 030 spools have open crossover.

**Bold: Designates Tier I products and options.**

**Non-Bold: Designates Tier II products and options. These products will have longer lead times.**

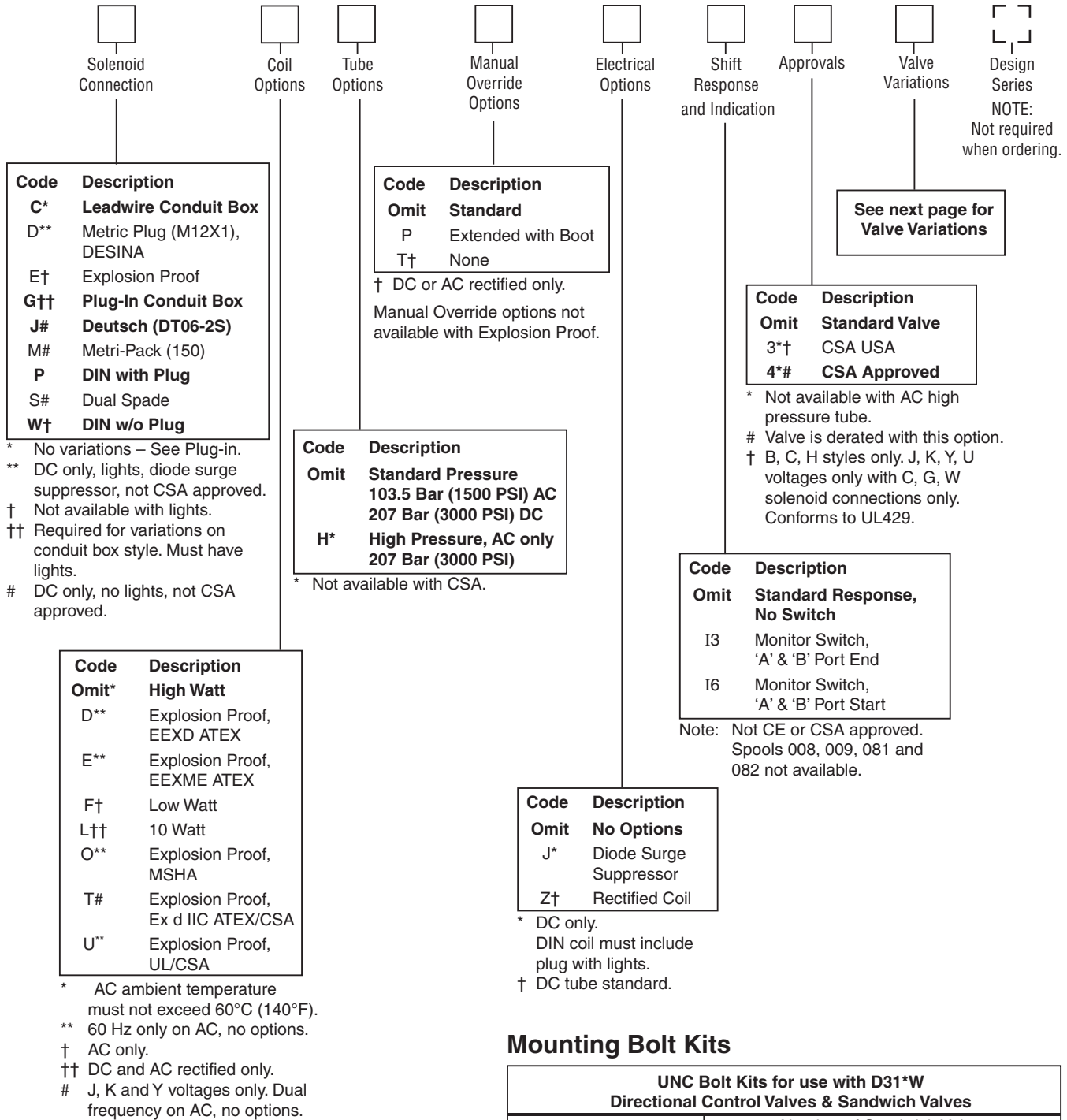

**Valve Weight:**  
 Double Solenoid 5.4 kg (12.0 lbs.)

**Seal Kit:**  
 Nitrile SKD31VWN91  
 Fluorocarbon SKD31VWV91

**Mounting Bolt Kits**

UNC Bolt Kits for use with D31*W Directional Control Valves & Sandwich Valves					
		Number of Sandwich Valves @ 2.00" (50mm) thickness			
		0	1	2	3
D31*W	Standard:	BK98 1.62"	BK141 3.50"	BK142 5.50"	BK143 7.50"
	Metric:	BKM98 40mm	BKM141 90mm	BKM142 140mm	BKM143 190mm

NOTE: All bolts are SAE grade 8. Standard bolts are 1/4-20 UNCA thread. Metric bolts are M6-1.0 thread. Torque to 16 Nm (12 ft-lbs).

**Bold: Designates Tier I products and options.**

**Non-Bold: Designates Tier II products and options. These products will have longer lead times.**

**Valve Variations**

**A**

Code	Description
<b>5*</b>	<b>Signal Lights – Standard</b>
	<b>Signal Lights – Hirsch. (DIN with Plug)</b>
7B**	Manaplug – Brad Harrison (12x1) Micro with Lights
<b>56**</b>	<b>Manaplug (Mini) with Lights</b>
<b>20</b>	<b>Fast Response</b>
<b>1C**</b>	<b>Manaplug (Mini) Single Sol. 5-pin, with Lights</b>
1D**	Manaplug (Micro) Single Sol. 5-pin, with Lights
1G**	Manaplug (Mini) Single Sol. 5-pin, with Stroke Adjust 'A' & 'B' End and Lights
1H**	Manaplug (Micro) Single Sol. 5-pin, with Stroke Adjust 'A' & 'B' End and Lights
1M**	Manaplug Opposite Normal
1P	Painted Body
1R	Stroke Adjust 'A' & 'B' End with Pilot Choke Meter In
<b>3A</b>	<b>Pilot Choke Meter Out</b>
<b>3B</b>	<b>Pilot Choke Meter In</b>
<b>3C</b>	<b>Pilot Pressure Reducer</b>
3D	Stroke Adjust 'B' End
3E	Stroke Adjust 'A' End
3F	Stroke Adjust 'A' & 'B' End
<b>3G*</b>	<b>Pilot Choke Meter Out with Lights</b>
<b>3H*</b>	<b>Pilot Choke Meter In with Lights</b>
3J*	Pilot Pressure Reducer with Lights
3K	Pilot Choke Meter Out with Stroke Adjust 'A' & 'B' End
3L**	Pilot Choke Meter Out, Stroke Adjust 'A' & 'B' End with Lights and Manaplug — Brad Harrison Mini
3M	Pilot Choke Meter Out, Pilot Pressure Reducer, Stroke Adjust 'A' & 'B' End
3R	Pilot Choke Meter Out & Pilot Pressure Reducer
3S**	Lights, Mini Manaplug, Pilot Choke Meter Out
7Y**	M12x1 Manaplug (4-pin), Special Wiring, and Lights

\* DESINA, plug-in conduit box, and DIN with plug styles only.

\*\* Must have plug-in style conduit box.

**D31 Series Pressure Drop vs. Flow**

The chart below provides the flow vs. pressure drop curve reference for the D31 Series valves by spool type.

Example:

Find the pressure drop at 76 LPM (20 GPM) for a D31 with a number 1 spool. To the right of spool number 1, locate the number 3 in the P-A column, and 2 in the B-T column.

Using the graph at the bottom, locate curves 2 and 3 and read the pressure drop values. Total pressure drop through the valve is the sum of the two values.

*Note: Pressure drops should be checked for all flow paths, especially when using non-symmetrical spools (003, 005, 007, 014, 015 and 016) and unbalanced actuators.*

**D31 Pressure Drop Reference Chart**

Spool No.	Curve Number										
	Shifted				Center Condition						
	P-A	P-B	B-T	A-T	(P-T)	(B-A)	(A-B)	(P-A)	(P-B)	(A-T)	(B-T)
001	3	3	2	1	-	-	-	-	-	-	-
002	3	3	1	1	3	3	3	4	4	1	1
003	3	3	1	1	-	-	-	-	-	3	-
004	3	3	1	1	-	-	-	-	-	1	1
005	3	3	1	1	-	-	-	5	-	-	-
006	3	3	1	1	-	5	7	6	5	-	-
007	4	2	1	1	4	-	-	-	3	-	2
009	3	3	1	1	7	-	-	-	-	-	-
010	3	2	-	-	-	-	-	-	-	-	-
011	3	2	1	1	-	-	-	-	-	8	8
014	2	4	1	1	4	-	-	4	-	2	-
015	3	2	4	1	-	-	-	-	-	-	4
016	5	2	1	1	-	-	-	-	5	-	-
020	5	4		2	2	-	-	-	-	-	-
030	4	3		1	1	-	-	-	-	-	-



**Viscosity Correction Factor**

Viscosity (SSU)	75	150	200	250	300	350	400
% of ΔP (Approx.)	93	111	119	126	132	137	141

Curves were generated using 110 SSU hydraulic oil.  
 For any other viscosity, pressure drop will change per chart.

**Performance Curves**

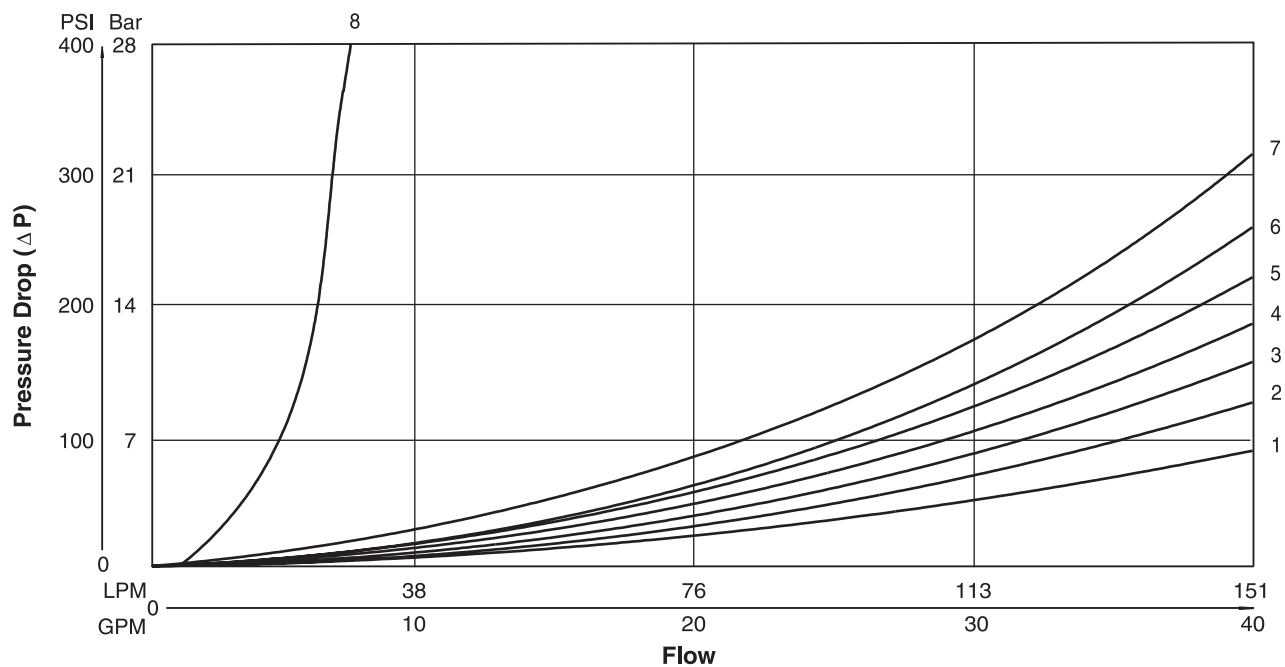



**Solenoid Ratings**

<b>Insulation System</b>	Class F
<b>Allowable Deviation from rated voltage</b>	-15% to +10% for DC and AC rectified coils -5% to +5% for AC Coils
<b>Armature</b>	Wet pin type
<b>CSA File Number</b>	LR60407
<b>Environmental Capability</b>	DC Solenoids meet NEMA 4 and IP67 when properly wired and installed. Contact HVD for AC coil applications.

**Explosion Proof Solenoid Ratings\***

<b>U.L. &amp; CSA (EU)</b>	Class I, Div 1 & 2, Groups C & D Class II, Div 1 & 2, Groups E, F & G As defined by the N.E.C.
<b>MSHA (EO)</b>	Complies with 30CFR, Part 18
<b>ATEX (ED)</b>	Complies with ATEX requirements for: Exd, Group IIB; EN50014: 1999+ Amds. 1 & 2, EN50018: 2000
<b>ATEX &amp; CSA/US (ET)</b>	Complies with ATEX EN60079-0, EN60079-1 Ex d IIC; CSA/US Ex d IIC, AEx d IIC for Class I, Zone 1, UL1203, UL1604, CSA E61241,1 Class II, Div 1

\* Allowable Voltage Deviation ±10%.  
 Note that Explosion Proof AC coils are single frequency only.

Code		Voltage	In Rush Amps Amperage	In Rush VA	Holding Amps @ 3MM	Watts	Resistance
Voltage Code	Power Code						
D	L	120 VDC	N/A	N/A	0.09 Amps	10 W	1584.00 ohms
D	Omit	120 VDC	N/A	N/A	0.26 Amps	30 W	528.00 ohms
G	Omit	198 VDC	N/A	N/A	0.15 Amps	30 W	1306.80 ohms
J	L	24 VDC	N/A	N/A	0.44 Amps	10 W	51.89 ohms
J	Omit	24 VDC	N/A	N/A	1.32 Amps	30 W	17.27 ohms
K	L	12 VDC	N/A	N/A	0.88 Amps	10 W	12.97 ohms
K	Omit	12 VDC	N/A	N/A	2.64 Amps	30 W	4.32 ohms
L	L	6 VDC	N/A	N/A	1.67 Amps	10 W	3.59 ohms
L	Omit	6 VDC	N/A	N/A	5.00 Amps	30 W	1.20 ohms
Q	Omit	100 VAC / 60 Hz	2.05 Amps	170 VA	0.77 Amps	30 W	19.24 ohms
QD	F	100 VAC / 60 Hz	1.35 Amps	135 VA	0.41 Amps	18 W	31.20 ohms
QD	F	100 VAC / 50 Hz	1.50 Amps	150 VA	0.57 Amps	24 W	31.20 ohms
R	F	24/60 VAC, Low Watt	6.67 Amps	160 VA	2.20 Amps	23 W	1.52 ohms
T	Omit	240/60 VAC	0.83 Amps	199 VA	0.30 Amps	30 W	120.40 ohms
T	Omit	220/50 VAC	0.87 Amps	191 VA	0.34 Amps	30 W	120.40 ohms
T	F	240/60 VAC, Low Watt	0.70 Amps	168 VA	0.22 Amps	21 W	145.00 ohms
T	F	220/50 VAC, Low Watt	0.75 Amps	165 VA	0.26 Amps	23 W	145.00 ohms
U	L	98 VDC	N/A	N/A	0.10 Amps	10 W	960.00 ohms
U	Omit	98 VDC	N/A	N/A	0.31 Amps	30W	288.00 ohms
Y	Omit	120/60 VAC	1.7 Amps	204 VA	0.60 Amps	30 W	28.20 ohms
Y	Omit	110/50 VAC	1.7 Amps	187 VA	0.68 Amps	30 W	28.20 ohms
Y	F	120/60 VAC, Low Watt	1.40 Amps	168 VA	0.42 Amps	21 W	36.50 ohms
Y	F	110/50 VAC, Low Watt	1.50 Amps	165 VA	0.50 Amps	23 W	36.50 ohms
Z	L	250 VDC	N/A	N/A	0.04 Amps	10 W	6875.00 ohms
Z	Omit	250 VDC	N/A	N/A	0.13 Amps	30 W	1889.64 ohms
<b>Explosion Proof Solenoids</b>							
R		24/60 VAC	7.63 Amps	183 VA	2.85 Amps	27 W	1.99 ohms
T		240/60 VAC	0.76 Amps	183 VA	0.29 Amps	27 W	1.34 ohms
N		220/50 VAC	0.77 Amps	169 VA	0.31 Amps	27 W	1.38 ohms
Y		120/60 VAC	1.60 Amps	192 VA	0.58 Amps	27 W	33.50 ohms
P		110/50 VAC	1.47 Amps	162 VA	0.57 Amps	27 W	34.70 ohms
K		12 VDC	N/A	N/A	2.75 Amps	33 W	4.36 ohms
J		24 VDC	N/A	N/A	1.38 Amps	33 W	17.33 ohms
<b>"ET" Explosion Proof Solenoids</b>							
K		12 VDC	N/A	N/A	1.00 Amps	12 W	12.00 ohms
J		24 VDC	N/A	N/A	1.00 Amps	13 W	44.30 ohms
Y		120/60-50 VAC	N/A	N/A	0.16 Amps	17 W	667.00 ohms

D31.indd, dd



Inch equivalents for millimeter dimensions are shown in (\*\*)

**Conduit Box, Double AC Solenoid**

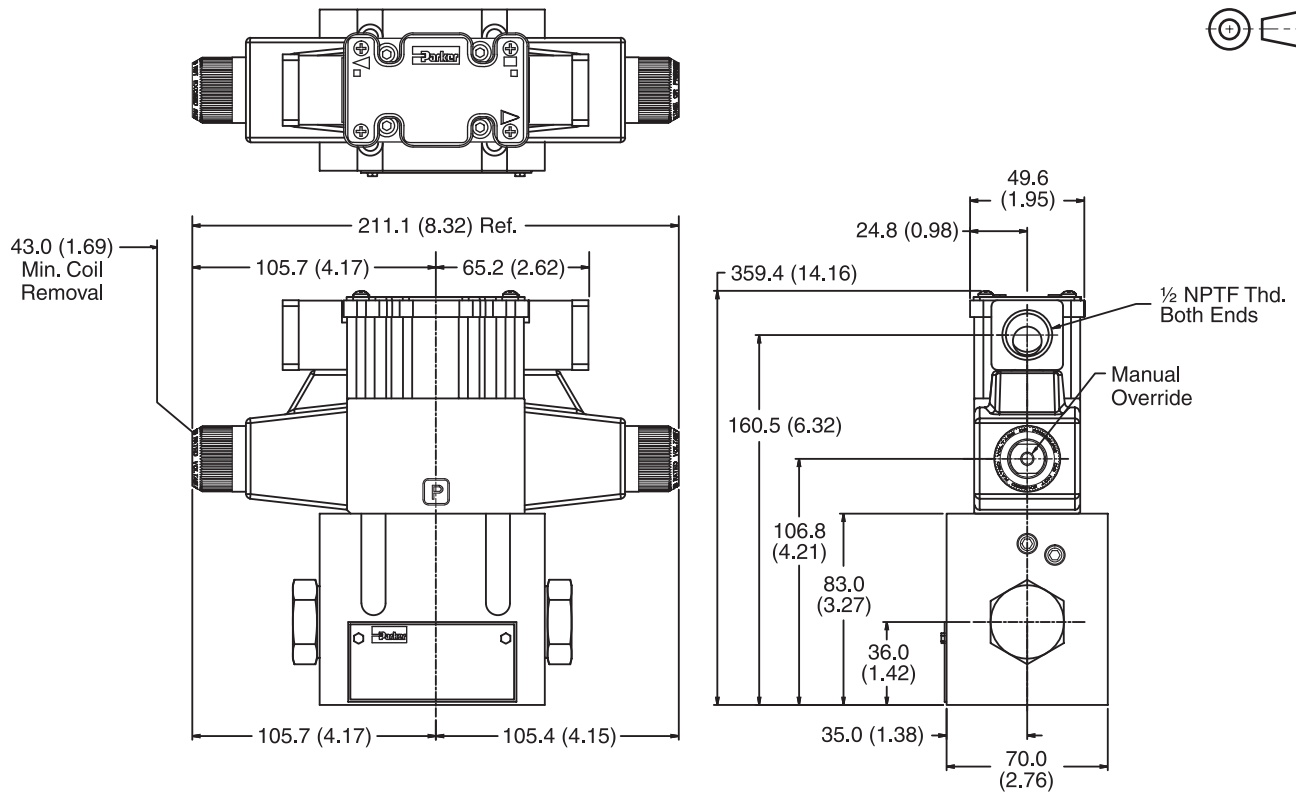

**Note:** 30.0mm (1.18") from bottom of bolt hole counterbore to bottom of valve.

**Conduit Box and Stroke Adjust, Double AC Solenoid**

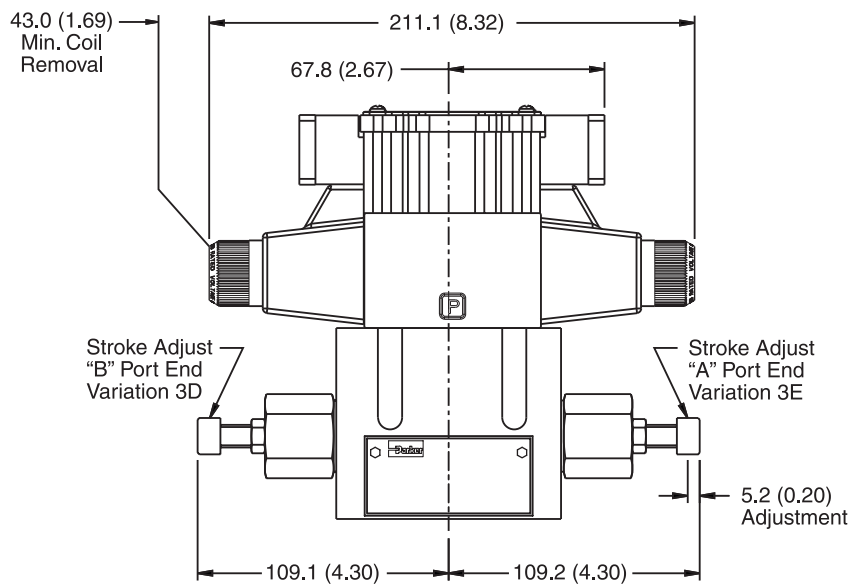

**Note:** 30.0mm (1.18") from bottom of bolt hole counterbore to bottom of valve.



Inch equivalents for millimeter dimensions are shown in (\*\*)

**A**

**Conduit Box and Pilot Choke Control, Double AC Solenoid**

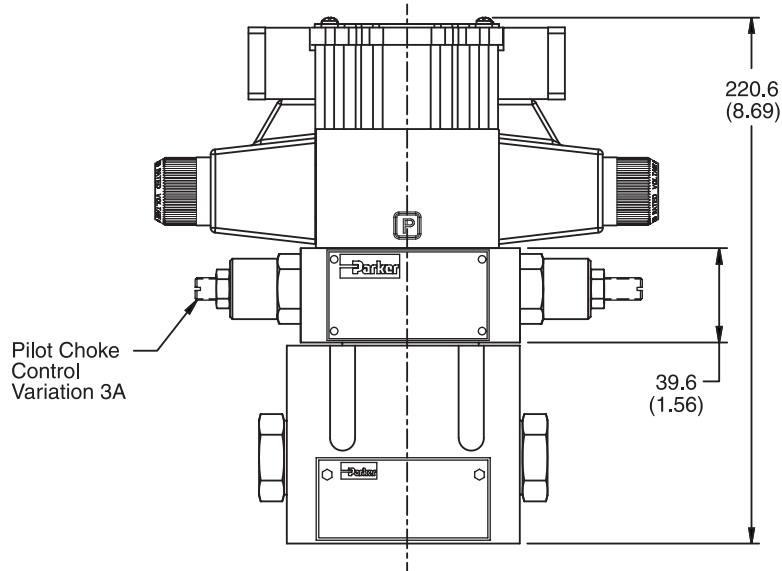

**Note:** 30.0mm (1.18") from bottom of bolt hole counterbore to bottom of valve.

**Conduit Box, Single AC Solenoid**

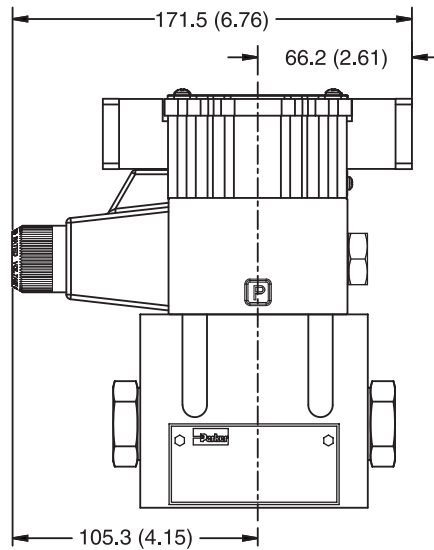

**Note:** 30.0mm (1.18") from bottom of bolt hole counterbore to bottom of valve.

Inch equivalents for millimeter dimensions are shown in (\*\*)

**Hirschmann and Stroke Adjust, Double DC Solenoid**

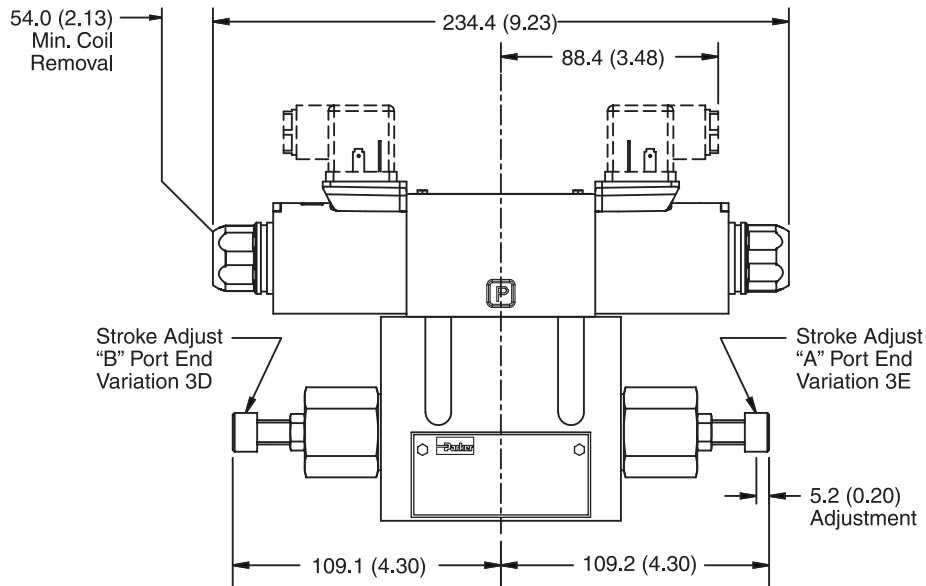

**Note:** 30.0mm (1.18") from bottom of bolt hole counterbore to bottom of valve.

**Hirschmann and Pilot Choke Control, Double DC Solenoid**

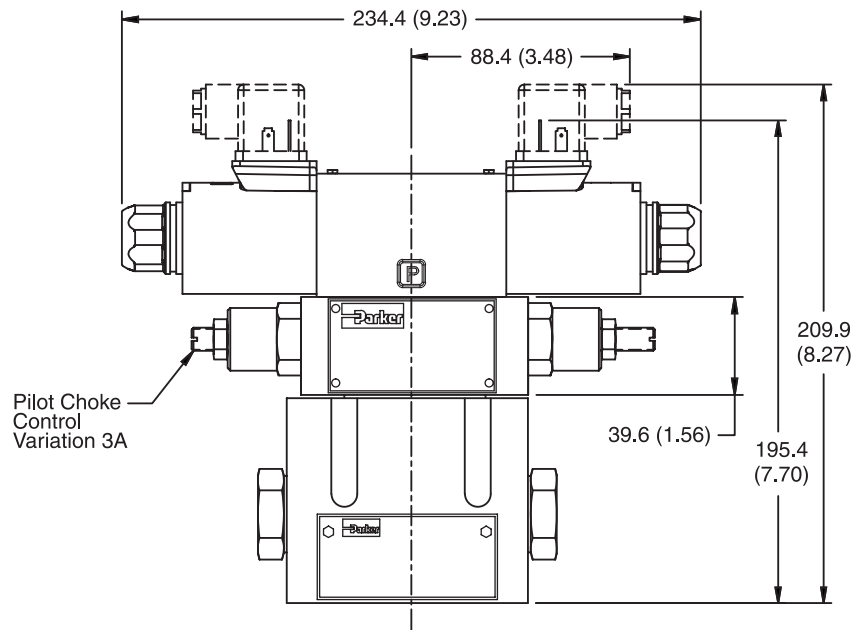

**Note:** 30.0mm (1.18") from bottom of bolt hole counterbore to bottom of valve.

Inch equivalents for millimeter dimensions are shown in (\*\*)

**A**

**Explosion Proof U.L. and C.S.A. Approved, Double Solenoid**

Note:  
2 Black Wires  
1 Green Wire

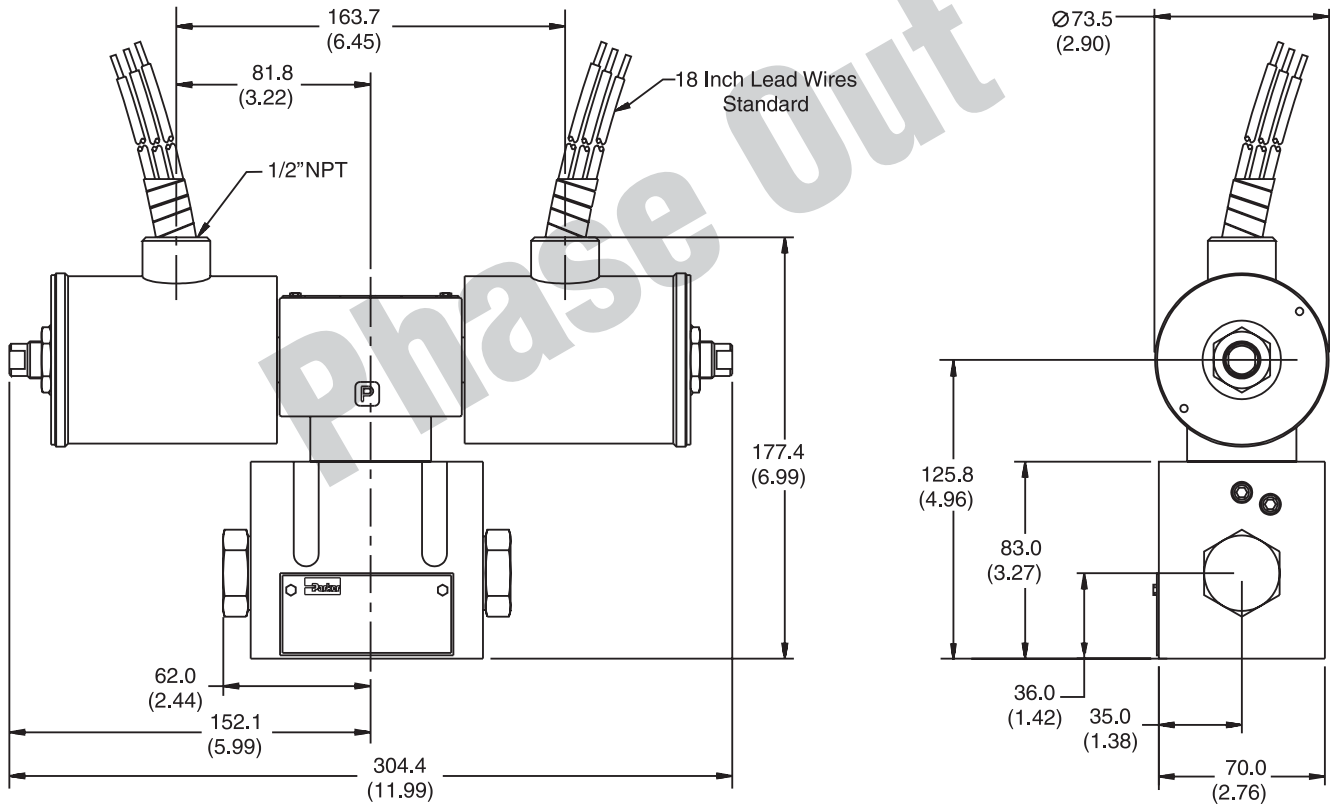

Inch equivalents for millimeter dimensions are shown in (\*\*)

**Explosion Proof, EX d IIC ATEX/CSA Single Solenoid**

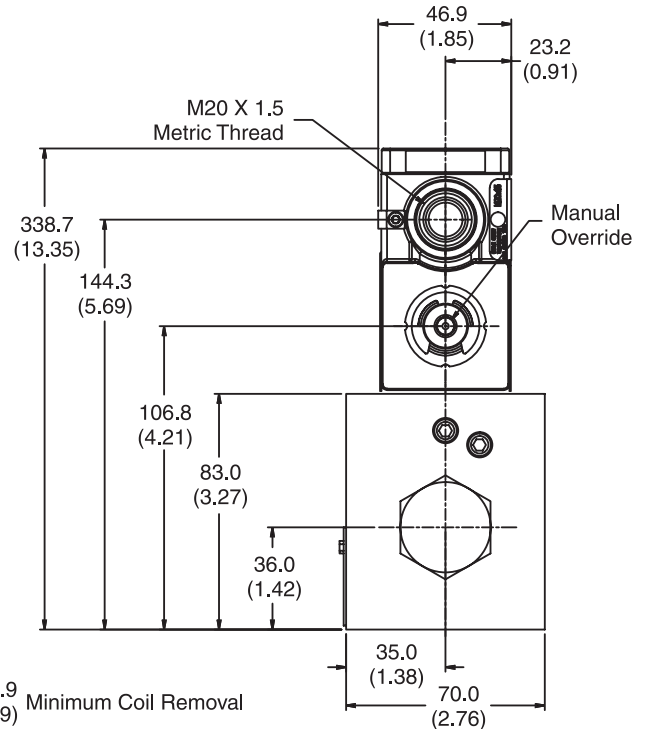
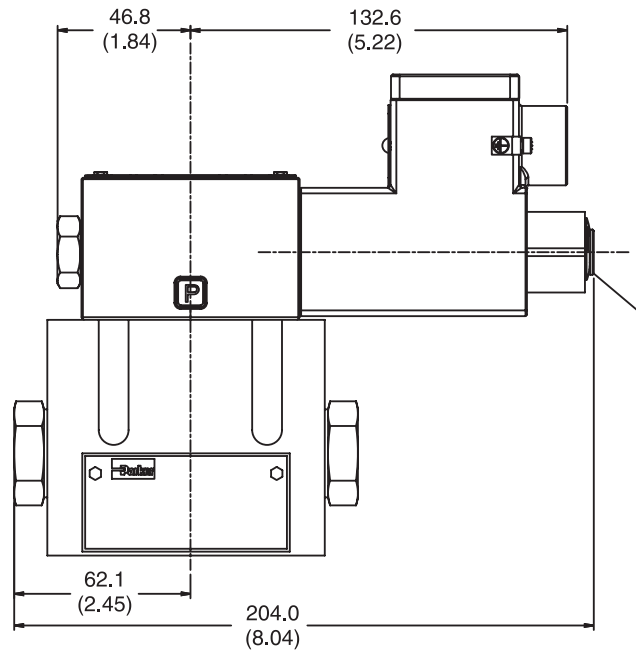

**Explosion Proof, EEXD ATEX, Single Solenoid**

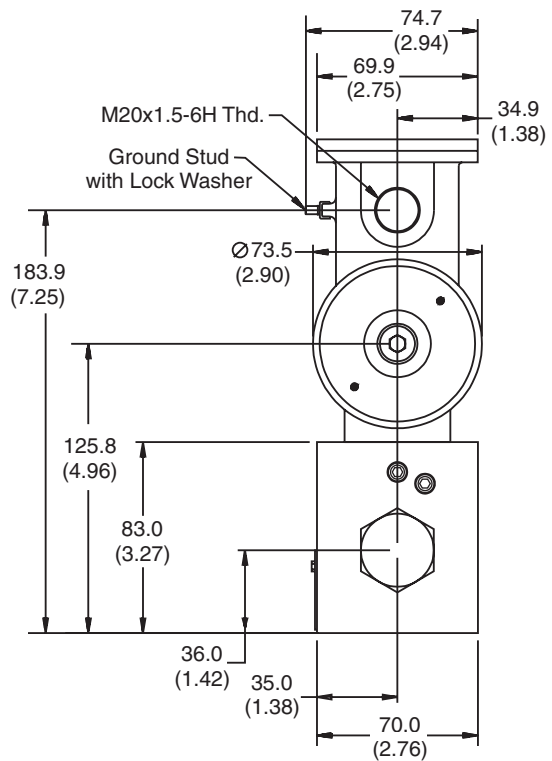
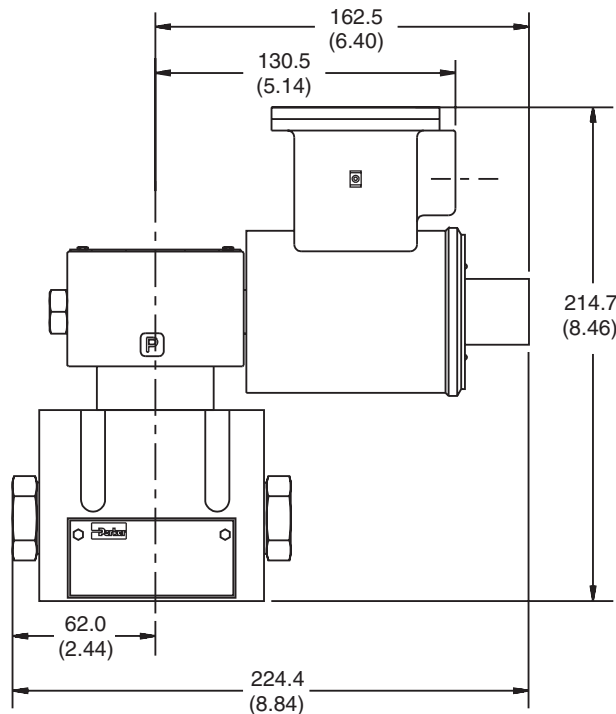

Inch equivalents for millimeter dimensions are shown in (\*\*)

**A**

**Plug-in Conduit Box, Double DC Solenoid**

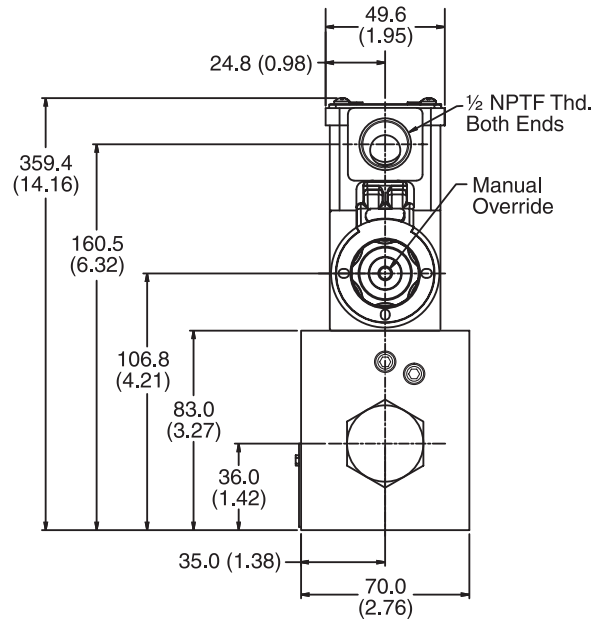
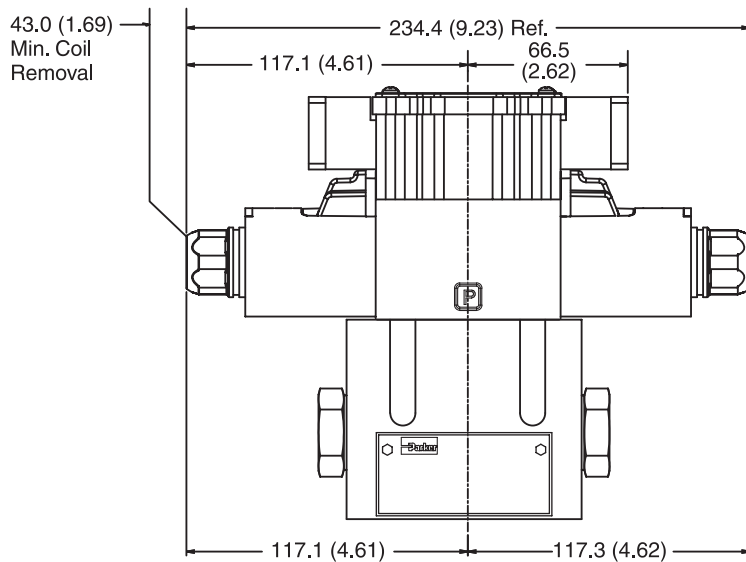
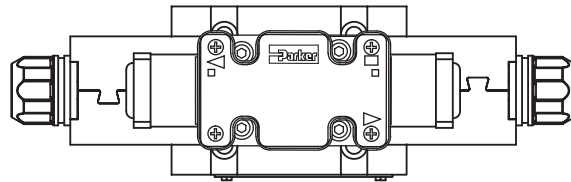

**Plug-in Conduit Box, Single DC Solenoid**

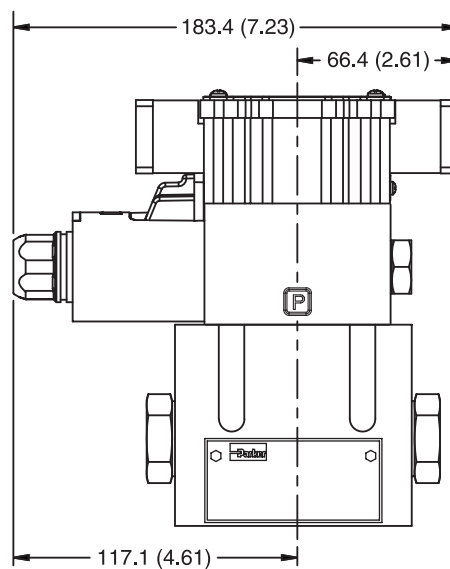

Inch equivalents for millimeter dimensions are shown in (\*\*)

**Plug-in Conduit Box, Double DC Solenoid with Variation I3 (Monitor Switch)**



**Double Solenoid.** With solenoid "A" energized, flow path is P→A and B→T. When solenoid "B" is energized, flow path is P→B and A→T. The center condition on a spring-centered valve exists when both coils are de-energized, or during a complete shift, as the spool passes through center.

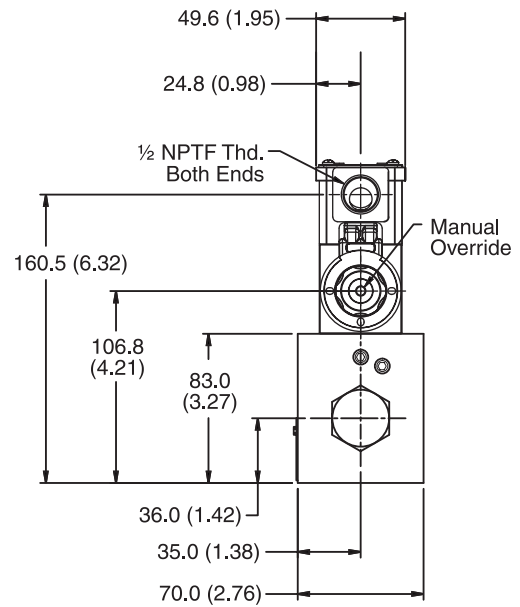
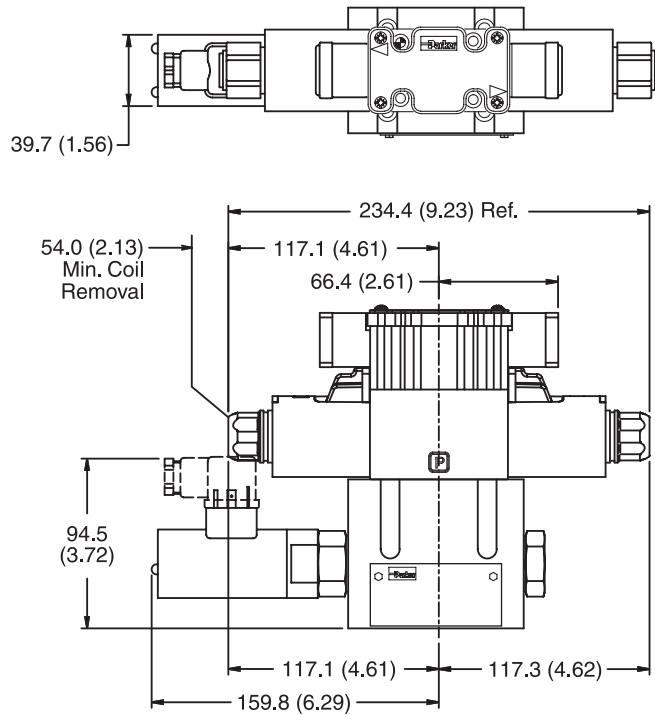

**Monitor Switch  
(Variation I3 and I6)**

This feature provides for electrical confirmation of the spool shift. This can be used in safety circuits, to assure proper sequencing, etc.

**Switch Data**

Pin 1 and Pin 3 have outputs equal to the input. When the monitor switch has the output to Pin 1, Pin 3 will have an output of zero, and vice-versa. When the valve is switched, Pin 1 and Pin 3 will switch outputs.

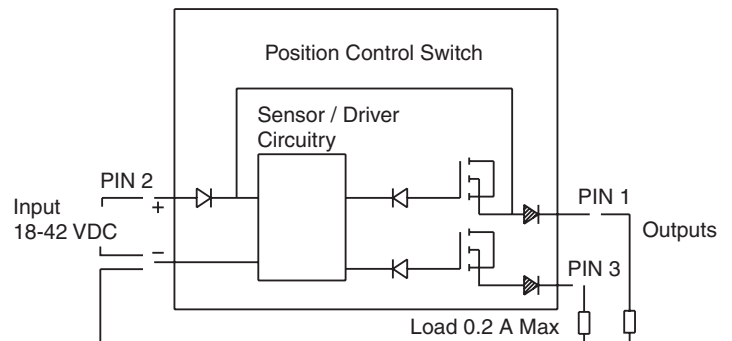



**Manaplug (Options 6, 56, 1A & 1C)**

- Interface – Brad Harrison Plug
- 3-Pin for Single Solenoid
  - 5-Pin for Double Solenoid

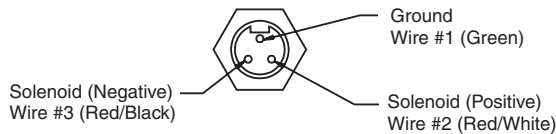

**3-Pin Manaplug (Mini) with Lights**

Single Solenoid Valves – Installed Opposite Side of Solenoid

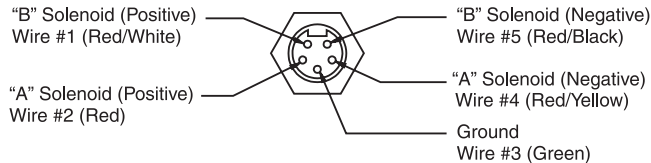

**5-Pin Manaplug (Mini) with Lights**

Single Solenoid Valves – Installed Opposite Side of Solenoid  
 Double Solenoid Valves – Installed Over "A" Solenoid  
 ("A" and "B" Solenoids Reversed for #8 and #9 Spools)

**Micro Connector Options (7A, 7B, 1B & 1D)**

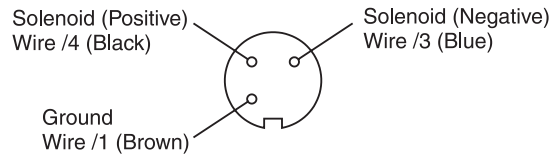

**3-Pin Manaplug (Micro) with Lights**

Single Solenoid Valves – Installed Opposite Side of Solenoid

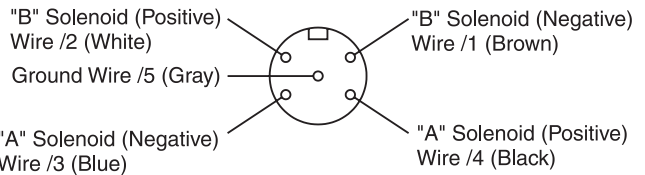

**5-Pin Manaplug (Micro) with Lights**

Single Solenoid Valves – Installed Opposite Side of Solenoid  
 Double Solenoid Valves – Installed Over "A" Solenoid  
 ("A" and "B" Solenoids Reversed for #8 and #9 Spools)

**Pins are as seen on valve (male pin connectors)**

**Manaplug – Electrical Mini Plug**

- EP336-30** 3 Pin Plug
- EP316-30** 5 Pin Plug (Double Solenoid)
- EP31A-30** 5 Pin Plug (Single Solenoid)

**Manaplug – Electrical Micro Plug**

- EP337-30** 3 Pin Plug
- EP317-30** 5 Pin Plug (Double Solenoid)
- EP31B-30** 5 Pin Plug (Single Solenoid)

**Conduit Box Option C**

- No Wiring Options Available

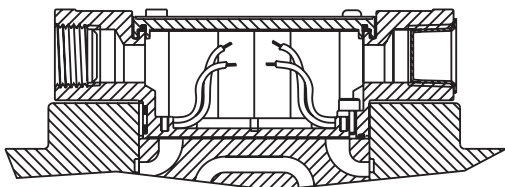

**Signal Lights (Option 5) – Plug-in Only**

- LED Interface
- Meets Nema 4/IP67

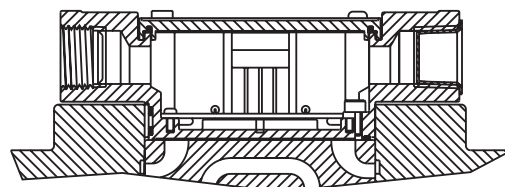

**Hirschmann Plug with Lights (Option P5)**  
**ISO 4400/DIN 43650 Form "A"**

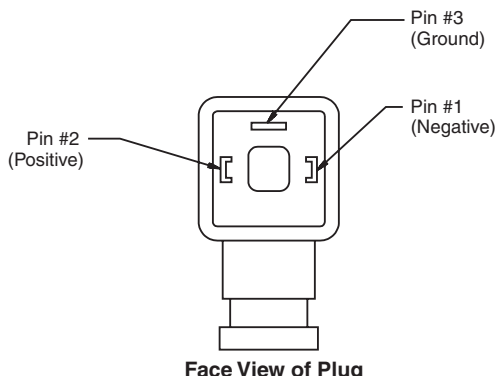

Face View of Plug

**DESINA Connector (Option D)**  
**M12 pin assignment**  
**Standard**

- 1 = Not used
- 2 = Not used
- 3 = 0V
- 4 = Signal (24 V)
- 5 = Earth Ground

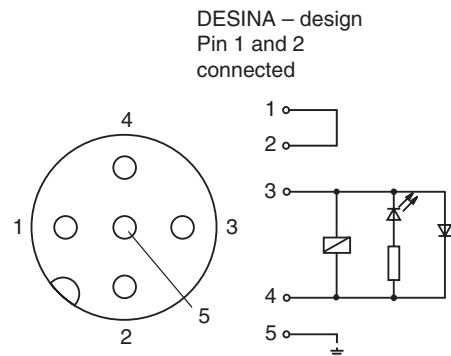

**Pins are as seen on valve (male pin connectors)**

**General Description**

Series D31NW valves are piloted by a D1VW valve. The valves can be ordered with position control.

The minimum pilot pressure must be ensured for all operating conditions of the directional valve.

Additionally spools with a P to T connection in the de-energized position need an external pressure supply (external inlet) or an integral check valve.

**Features**

- **World design** – Available worldwide.
- **Mounting bolts below center line of spool** – Minimizes spool binding.
- **Five chamber style** – Eliminates pressure spikes in tubes, increasing valve life.
- **High pressure and flow ratings** – Increased performance options in a compact valve.

**Dimensions**

Inch equivalents for millimeter dimensions are shown in (\*\*)

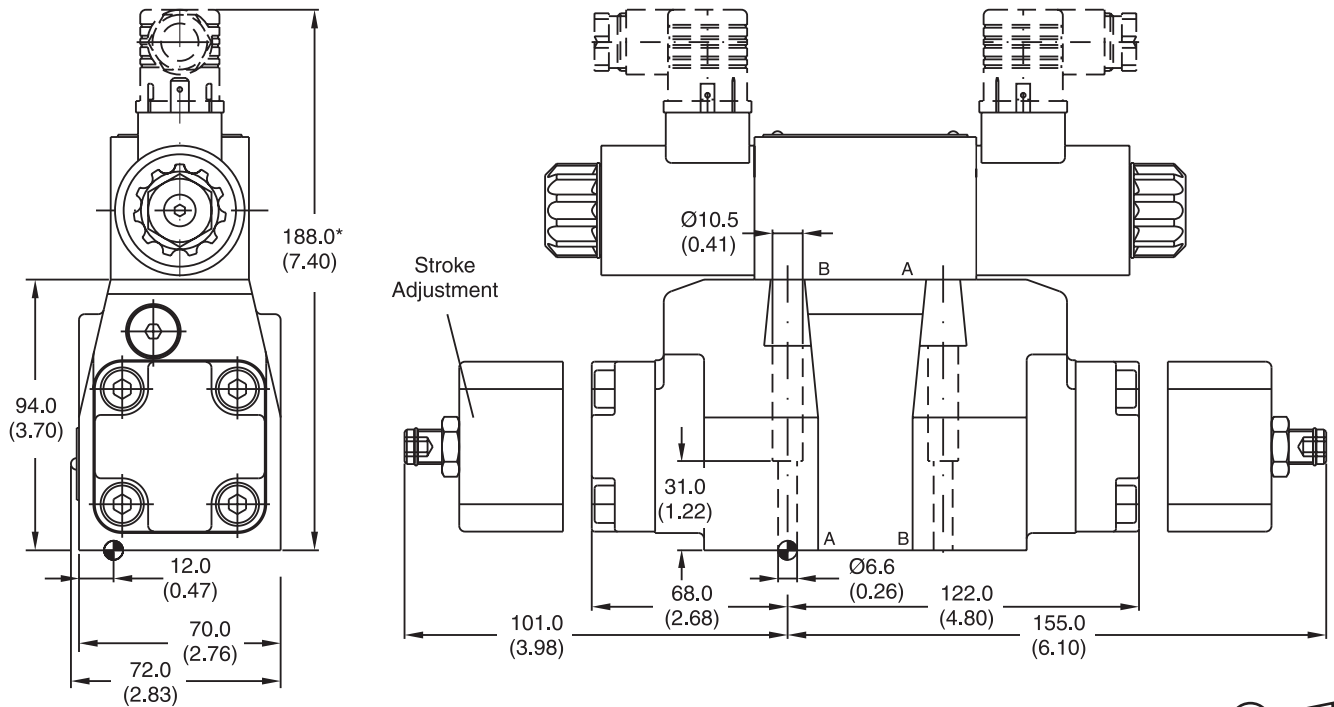

\* Please add for each sandwich plate +40mm (1.58") (pressure reducing valve, pilot choke valve meter-in/-out).

Surface Finish	Kit			Seal Kit
	BK385	4x M6x40 DIN 912 12.9	13.2 Nm (9.7 lb.-ft.)	Nitrile: SK-D31NW-N-91 Fluorocarbon: SK-D31NW-V-91

The space necessary to remove the plug per DIN 43650, design type AF is at least 15 mm.

The torque for the screw M3 of the plug has to be 0.5 to 0.6 Nm.

D31.indd, dd





**A**

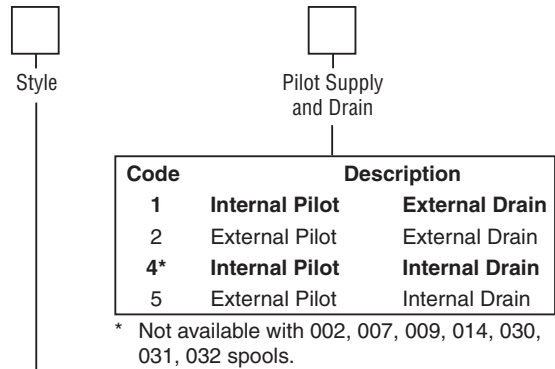
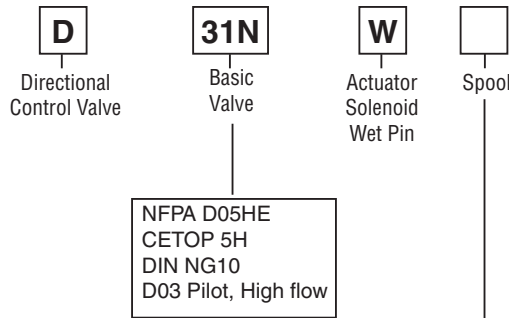

3-Position Spools	
Code	Spool Type
	a 0 b
001	
002	
003	
004	
005	
006	
007	
009	
011	
014	
015	
016	
021	
022	
031	
032	
081	
082	

2-Position Spools	
Code	Spool Type
	a b
020	
026	
030	

3-Position Spools		
Code	All 3-Position Spools	
<b>C</b>		<b>3 positions.</b> Spring offset in position "0". Operated in position "a" or "b".
	<b>Standard</b>	<b>Spool Type 009</b>
<b>E</b>	 Operated in position "a".	 Operated in position "b".
<b>F</b>	 Spring offset in position "b".	 Spring offset in position "a".
<b>K</b>	 Operated in position "b".	 Operated in position "a".
<b>M</b>	 Spring offset in position "a".	 Spring offset in position "b".
<b>R</b>	 No center in offset position.	 No center in offset position.
<b>S</b>	 No center in offset position.	 No center in offset position.

2-Position Spools		
Code	Spool Position	
<b>B</b>		<b>Spring offset in position "b".</b> <b>Operated in position "a".</b>
<b>D</b>		Detent, operated in position "a" or "b". No center or offset position.
<b>H</b>		Spring offset in position "a". Operated in position "b".

**Weight:**  
 Single Solenoid: 7.6 kg (16.8 lbs.)  
 Double Solenoid: 8.1 kg (17.9 lbs.)

**Bold: Designates Tier I products and options.**

**Non-Bold: Designates Tier II products and options. These products will have longer lead times.**

D31.indd, dd



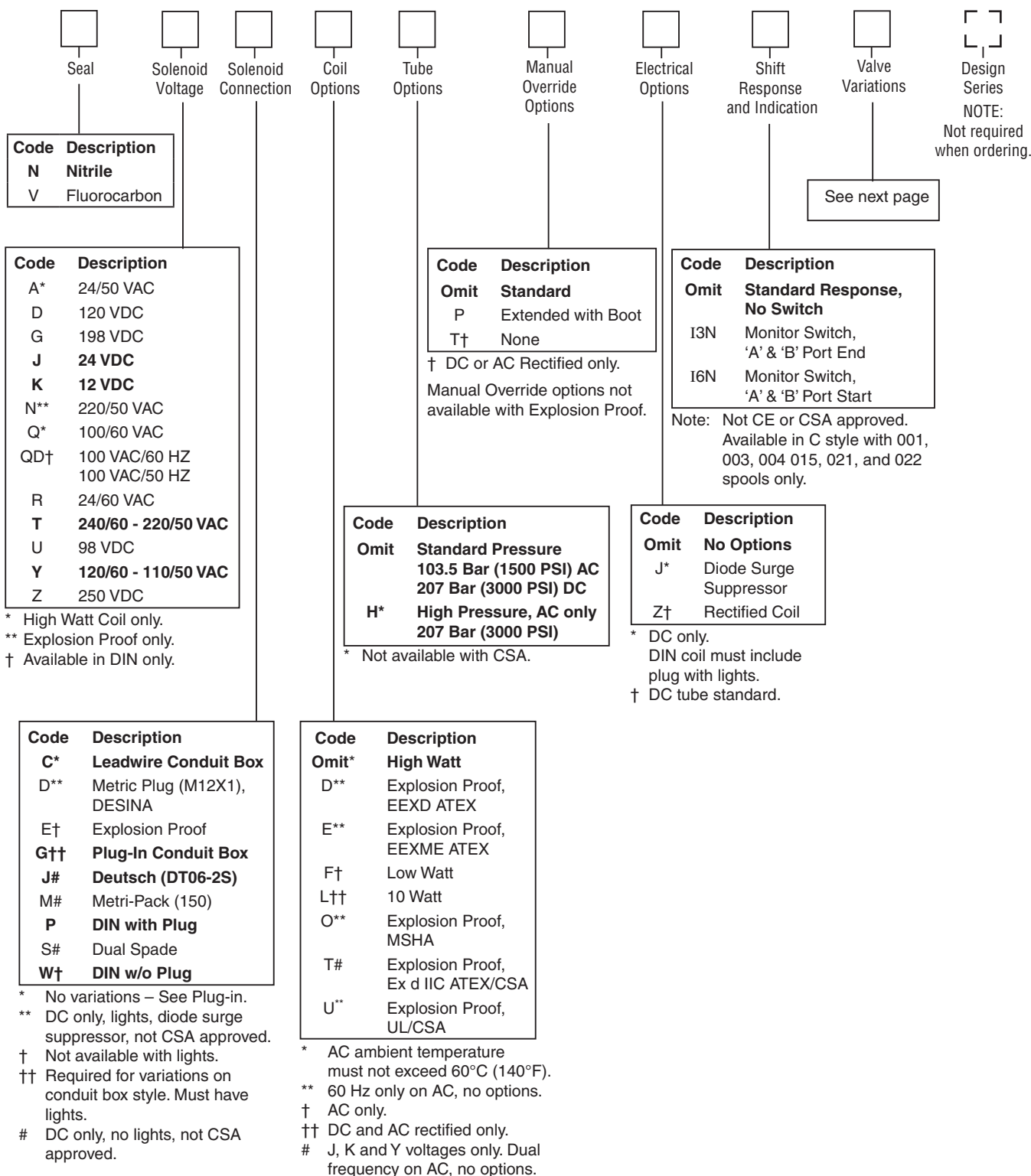

**Bold: Designates Tier I products and options.**

**Non-Bold: Designates Tier II products and options. These products will have longer lead times.**

**Valve Variations**

**A**

Code	Description
<b>5*</b>	<b>Signal Lights – Standard</b>
	<b>Signal Lights – Hirsch. (DIN with Plug)</b>
7B**	Manaplug – Brad Harrison (12x1) Micro with Lights
<b>56**</b>	<b>Manaplug (Mini) with Lights</b>
<b>1C**</b>	<b>Manaplug (Mini) Single Sol. 5-pin, with Lights</b>
1D**	Manaplug (Micro) Single Sol. 5-pin, with Lights
1G**	Manaplug (Mini) Single Sol. 5-pin, with Stroke Adjust 'A' & 'B' End and Lights
1H**	Manaplug (Micro) Single Sol. 5-pin, with Stroke Adjust 'A' & 'B' End and Lights
1M**	Manaplug Opposite Normal
1R	Stroke Adjust 'A' & 'B' End with Pilot Choke Meter In
<b>3A</b>	<b>Pilot Choke Meter Out</b>
<b>3B</b>	<b>Pilot Choke Meter In</b>
<b>3C</b>	<b>Pilot Pressure Reducer</b>
3D	Stroke Adjust 'B' End
3E	Stroke Adjust 'A' End
3F	Stroke Adjust 'A' & 'B' End
<b>3G*</b>	<b>Pilot Choke Meter Out with Lights</b>
<b>3H*</b>	<b>Pilot Choke Meter In with Lights</b>
3J*	Pilot Pressure Reducer with Lights
3K	Pilot Choke Meter Out with Stroke Adjust 'A' & 'B' End
3L**	Pilot Choke Meter Out, Stroke Adjust 'A' & 'B' End with Lights and Manaplug — Brad Harrison Mini
3M	Pilot Choke Meter Out, Pilot Pressure Reducer, Stroke Adjust 'A' & 'B' End
3R	Pilot Choke Meter Out & Pilot Pressure Reducer
3S**	Lights, Mini Manaplug, Pilot Choke Meter Out
7Y**	M12x1 Manaplug (4-pin), Special Wiring, and Lights

\* DESINA, plug-in conduit box, and DIN with plug styles only.

\*\* Must have plug-in style conduit box.

**Solenoid Ratings**

<b>Insulation System</b>	Class F
<b>Allowable Deviation from rated voltage</b>	-15% to +10% for DC and AC rectified coils -5% to +5% for AC Coils
<b>Armature</b>	Wet pin type
<b>CSA File Number</b>	LR60407
<b>Environmental Capability</b>	DC Solenoids meet NEMA 4 and IP67 when properly wired and installed. Contact HVD for AC coil applications.

**Explosion Proof Solenoid Ratings\***

<b>U.L. &amp; CSA (EU)</b>	Class I, Div 1 & 2, Groups C & D Class II, Div 1 & 2, Groups E, F & G As defined by the N.E.C.
<b>MSHA (EO)</b>	Complies with 30CFR, Part 18
<b>ATEX (ED)</b>	Complies with ATEX requirements for: Exd, Group IIB; EN50014: 1999+ Amds. 1 & 2, EN50018: 2000
<b>ATEX &amp; CSA/US (ET)</b>	Complies with ATEX EN60079-0, EN60079-1 Ex d IIC; CSA/US Ex d IIC, AEx d IIC for Class I, Zone 1, UL1203, UL1604, CSA E61241,1 Class II, Div 1



\* Allowable Voltage Deviation ±10%.  
 Note that Explosion Proof AC coils are single frequency only.

Code		Voltage	In Rush Amps Amperage	In Rush VA	Holding Amps @ 3MM	Watts	Resistance
Voltage Code	Power Code						
D	L	120 VDC	N/A	N/A	0.09 Amps	10 W	1584.00 ohms
D	Omit	120 VDC	N/A	N/A	0.26 Amps	30 W	528.00 ohms
G	Omit	198 VDC	N/A	N/A	0.15 Amps	30 W	1306.80 ohms
J	L	24 VDC	N/A	N/A	0.44 Amps	10 W	51.89 ohms
J	Omit	24 VDC	N/A	N/A	1.32 Amps	30 W	17.27 ohms
K	L	12 VDC	N/A	N/A	0.88 Amps	10 W	12.97 ohms
K	Omit	12 VDC	N/A	N/A	2.64 Amps	30 W	4.32 ohms
L	L	6 VDC	N/A	N/A	1.67 Amps	10 W	3.59 ohms
L	Omit	6 VDC	N/A	N/A	5.00 Amps	30 W	1.20 ohms
Q	Omit	100 VAC / 60 Hz	2.05 Amps	170 VA	0.77 Amps	30 W	19.24 ohms
QD	F	100 VAC / 60 Hz	1.35 Amps	135 VA	0.41 Amps	18 W	31.20 ohms
QD	F	100 VAC / 50 Hz	1.50 Amps	150 VA	0.57 Amps	24 W	31.20 ohms
R	F	24/60 VAC, Low Watt	6.67 Amps	160 VA	2.20 Amps	23 W	1.52 ohms
T	Omit	240/60 VAC	0.83 Amps	199 VA	0.30 Amps	30 W	120.40 ohms
T	Omit	220/50 VAC	0.87 Amps	191 VA	0.34 Amps	30 W	120.40 ohms
T	F	240/60 VAC, Low Watt	0.70 Amps	168 VA	0.22 Amps	21 W	145.00 ohms
T	F	220/50 VAC, Low Watt	0.75 Amps	165 VA	0.26 Amps	23 W	145.00 ohms
U	L	98 VDC	N/A	N/A	0.10 Amps	10 W	960.00 ohms
U	Omit	98 VDC	N/A	N/A	0.31 Amps	30W	288.00 ohms
Y	Omit	120/60 VAC	1.7 Amps	204 VA	0.60 Amps	30 W	28.20 ohms
Y	Omit	110/50 VAC	1.7 Amps	187 VA	0.68 Amps	30 W	28.20 ohms
Y	F	120/60 VAC, Low Watt	1.40 Amps	168 VA	0.42 Amps	21 W	36.50 ohms
Y	F	110/50 VAC, Low Watt	1.50 Amps	165 VA	0.50 Amps	23 W	36.50 ohms
Z	L	250 VDC	N/A	N/A	0.04 Amps	10 W	6875.00 ohms
Z	Omit	250 VDC	N/A	N/A	0.13 Amps	30 W	1889.64 ohms
<b>Explosion Proof Solenoids</b>							
R		24/60 VAC	7.63 Amps	183 VA	2.85 Amps	27 W	1.99 ohms
T		240/60 VAC	0.76 Amps	183 VA	0.29 Amps	27 W	1.34 ohms
N		220/50 VAC	0.77 Amps	169 VA	0.31 Amps	27 W	1.38 ohms
Y		120/60 VAC	1.60 Amps	192 VA	0.58 Amps	27 W	33.50 ohms
P		110/50 VAC	1.47 Amps	162 VA	0.57 Amps	27 W	34.70 ohms
K		12 VDC	N/A	N/A	2.75 Amps	33 W	4.36 ohms
J		24 VDC	N/A	N/A	1.38 Amps	33 W	17.33 ohms
<b>"ET" Explosion Proof Solenoids</b>							
K		12 VDC	N/A	N/A	1.00 Amps	12 W	12.00 ohms
J		24 VDC	N/A	N/A	1.00 Amps	13 W	44.30 ohms
Y		120/60-50 VAC	N/A	N/A	0.16 Amps	17 W	667.00 ohms

**A**

General			
<b>Design</b>		Directional Spool Valve	
<b>Actuation</b>		Solenoid	
<b>Size</b>		NG10	
<b>Mounting Interface</b>		DIN 24340 A10 / ISO 4401 / NFPA D05 / CETOP RP 121-H	
<b>Mounting Position</b>		Unrestricted, preferably horizontal	
<b>Ambient Temperature</b>		[°C]	-25...+50; (-13°F...+122°F) (without inductive position control)
		[°C]	0...+50; (+32°F...+122°F) (with inductive position control)
<b>MTTF<sub>D</sub> Value</b>		[years]	75
Hydraulic			
<b>Maximum Operating Pressure</b>		Pilot drain internal: P, A, B, X 315 Bar (4568 PSI); T, Y 140 Bar (2030 PSI) Pilot drain external: P, A, B, T, X 315 Bar (4568 PSI); Y 140 Bar (2030 PSI)	
<b>Fluid</b>		Hydraulic oil in accordance with DIN 51524 / 51525	
<b>Fluid Temperature</b>		[°C]	-25 ... +70 (-13°F...+158°F)
<b>Viscosity Permitted</b>		[cSt]/[mm <sup>2</sup> /s]	2.8...400 (13...1854 SSU)
<b>Recommended</b>		[cSt]/[mm <sup>2</sup> /s]	30...80 (139...371 SSU)
<b>Filtration</b>		ISO 4406 (1999); 18/16/13 (meet NAS 1638: 7)	
<b>Flow Maximum</b>		170 LPM (45 GPM)	
<b>Leakage at 350 Bar (per flow path)</b>		[ml/min]	72...422 (0.2...0.11 GPM) (depending on spool)
<b>Minimum Pilot Supply Pressure</b>		7 Bar (102 PSI)	
Static / Dynamic			
<b>Step Response at 85%</b>		Energized	
<b>DC Solenoids</b>		De-energized	
<b>Pilot Pressure</b>			
50 Bar & 100 Bar		[ms]	470
250 Bar & 350 Bar		[ms]	390
<b>AC Solenoids</b>			
<b>Pilot Pressure</b>			
50, 100, 250 & 350 Bar		[ms]	30 / 50
			375



### Position Control M12x1

<b>Protection Class</b>		IP 65 in accordance with EN 60529 (plugged and mounted)
<b>Ambient Temperature</b>	[°C]	0...+50; (+32°F...122°F)
<b>Supply Voltage / Ripple</b>	[V]	18...42 ±10%
<b>Current Consumption without Load</b>	[mA]	≤ 30
<b>Max. Output Current per Channel, Ohmic</b>	[mA]	400
<b>Min. Output Load per Channel, Ohmic [kOhm]</b>		100
<b>Max. Output Drop at 0.2A</b>	[V]	≤ 1.1
<b>Max. Output Drop at 0.4A</b>	[V]	≤ 1.6
<b>EMC</b>		EN50081-1 / EN50082-2
<b>Max. Tolerance Ambient Field Strength</b>	[A/m]	<1200
<b>Min. Distance to Next AC Solenoid</b>	[m]	>0.1
<b>Interface</b>		M12x1 per IEC 61076-2-101
<b>Wiring Minimum</b>	[mm²]	5 x 0.25 brad shield recommended
<b>Wiring Length Maximum</b>	[m]	50 (164 ft.) recommended

### M12 Pin Assignment

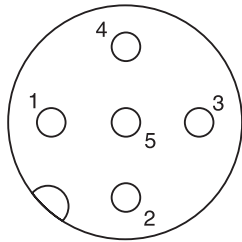

- 1 + Supply 18...42V
- 2 Out B: normally closed
- 3 0V
- 4 Out A: normally open
- 5 Earth ground

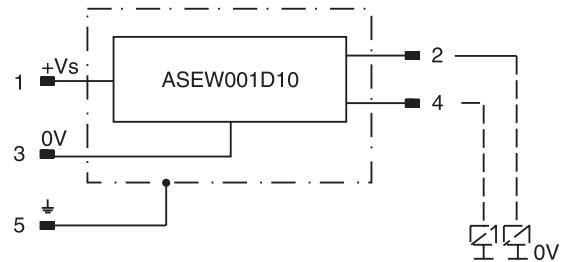

### Definitions

Start position monitored:

The valve is de-energized. The inductive switch gives a signal at the moment (below 15% spool stroke) when the spool leaves the spring offset position.

End position monitored:

The inductive switch gives a signal before the end position is reached. (above 85% spool stroke).

Delivery includes plug M12 x 1 (part no.: 5004109).

**Performance Curves**

The flow curve diagram shows the flow versus pressure drop curves for all spool types. The relevant curve number for each spool type, operating position and flow direction is given in the table below.

**A**

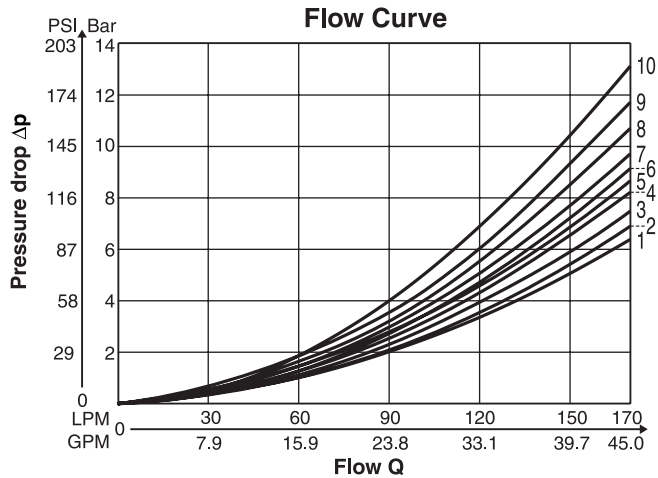

Spool Code	Curve Number				
	P-A	P-B	P-T	A-T	B-T
01	3	3	7	4	3
02	3	3	—	2	4
03	3	3	—	2	5
07	4	6	6	4	10
08	2	3	—	4	4
09	2	2	—	1	4
10	2	3	—	4	4
11	5	3	—	2	5
13	2	4	—	1	4
14	4	3	—	2	4

All characteristic curves measured with HLP46 at 50°C (122°F).

**Integral Check Valve in the P port**

Mounting an integral check valve in the P port is necessary to build up pilot pressure for valves with P to T connection and internal pilot oil supply. The pressure difference at the integral check valve (see performance curves) is to be added to all flow curves of the P-port of the main valve.

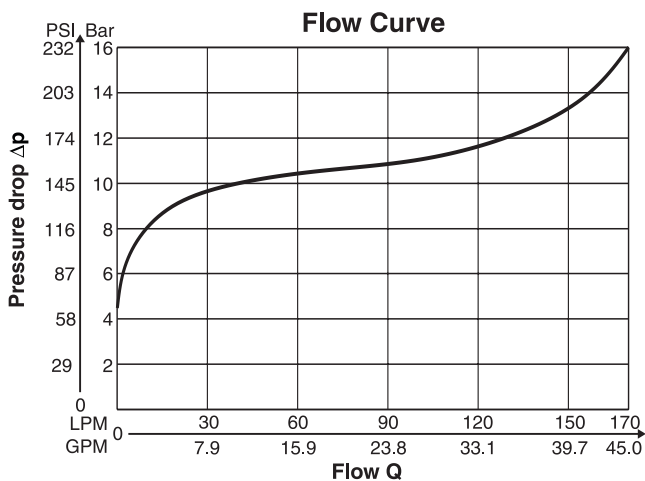

**Pilot Oil Inlet (Supply) and Outlet (Drain)**

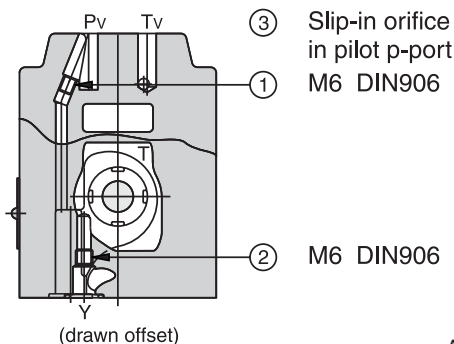

○ open, ● closed

Pilot Oil		1	2	3
Inlet	Outlet			
internal	external	○	●	Orifice Ø1.0
external	external	●	●	Orifice Ø1.0
internal	internal	○	○	Orifice Ø1.0
external	internal	●	○	Orifice Ø1.0

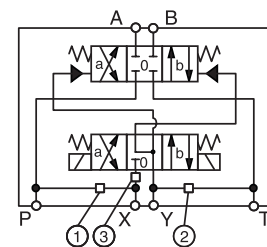

All orifice sizes for standard valves



**Manaplug (Options 6, 56, 1A & 1C)**

- Interface – Brad Harrison Plug
- 3-Pin for Single Solenoid
- 5-Pin for Double Solenoid

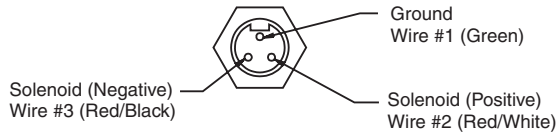

**3-Pin Manaplug (Mini) with Lights**

Single Solenoid Valves – Installed Opposite Side of Solenoid

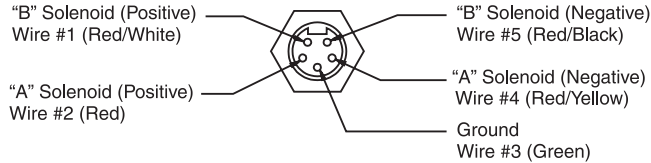

**5-Pin Manaplug (Mini) with Lights**

Single Solenoid Valves – Installed Opposite Side of Solenoid  
 Double Solenoid Valves – Installed Over "A" Solenoid  
 ("A" and "B" Solenoids Reversed for #8 and #9 Spools)

**Micro Connector Options (7A, 7B, 1B & 1D)**

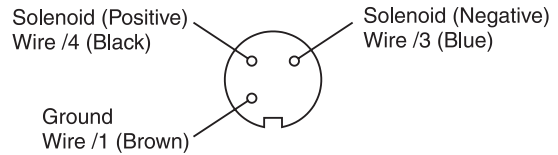

**3-Pin Manaplug (Micro) with Lights**

Single Solenoid Valves – Installed Opposite Side of Solenoid

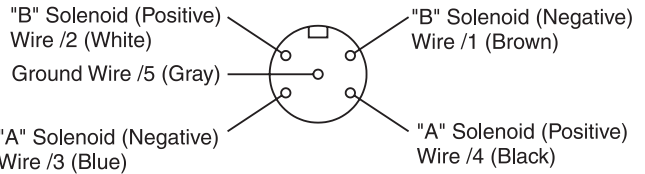

**5-Pin Manaplug (Micro) with Lights**

Single Solenoid Valves – Installed Opposite Side of Solenoid  
 Double Solenoid Valves – Installed Over "A" Solenoid  
 ("A" and "B" Solenoids Reversed for #8 and #9 Spools)

**Pins are as seen on valve (male pin connectors)**

**Manaplug – Electrical Mini Plug**

- EP336-30** 3 Pin Plug
- EP316-30** 5 Pin Plug (Double Solenoid)
- EP31A-30** 5 Pin Plug (Single Solenoid)

**Manaplug – Electrical Micro Plug**

- EP337-30** 3 Pin Plug
- EP317-30** 5 Pin Plug (Double Solenoid)
- EP31B-30** 5 Pin Plug (Single Solenoid)

**Conduit Box Option C**

- No Wiring Options Available

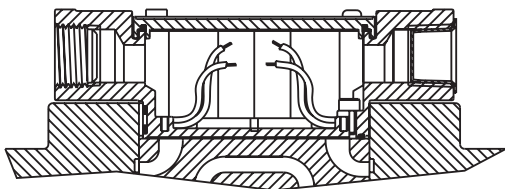

**Signal Lights (Option 5) — Plug-in Only**

- LED Interface
- Meets Nema 4/IP67

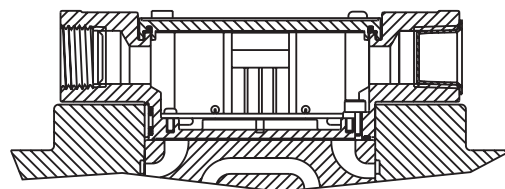

**Hirschmann Plug with Lights (Option P5)**  
**ISO 4400/DIN 43650 Form "A"**

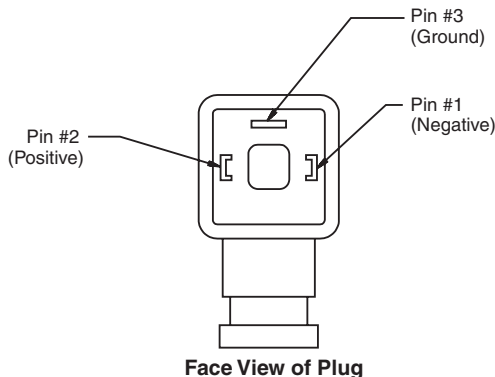

**Pins are as seen on valve (male pin connectors)**

**DESINA Connector (Option D)**  
**M12 pin assignment**  
**Standard**

- 1 = Not used
- 2 = Not used
- 3 = 0V
- 4 = Signal (24 V)
- 5 = Earth Ground

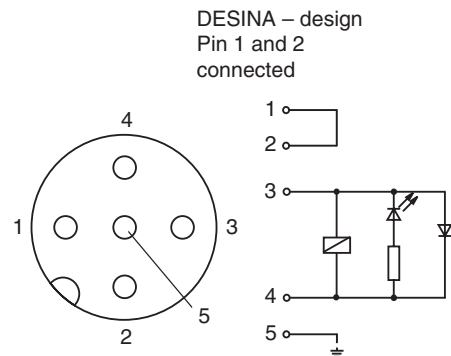



## General Description

Series D31\*A directional control valves are 5-chamber, air pilot operated valves. The valves are suitable for manifold or subplate mounting.

## Features

- **World design** – Available worldwide.
- **Mounting bolts below center line of spool** – Minimizes spool binding.
- **Five chamber style** – Eliminates pressure spikes in tubes, increasing valve life.
- **High pressure and flow ratings** – Increased performance options in a compact valve.

## Specifications

<b>Mounting Pattern</b>	NFPA D05H , CETOP 5 NFPA D05HE, CETOP 5H
<b>Max. Operating Pressure</b>	345 Bar (5000 PSI)
<b>Max. Tank Line Pressure</b>	Internal Drain Model: 34 Bar (500 PSI) External Drain Model: 207 Bar (3000 PSI)
<b>Max. Drain Pressure</b>	34 Bar (500 PSI)
<b>Maximum Flow</b>	See Switching Limit Charts
<b>Pilot Pressure</b>	Air Min: 3.4 Bar (50 PSI) Air Max: 10.2 Bar (150 PSI)
<b>Response Time</b>	Varies with pilot line size and length, pilot pressure, pilot valve shift time & flow capacity (GPM)

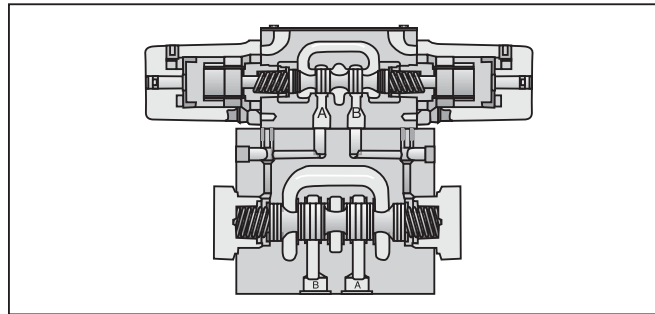
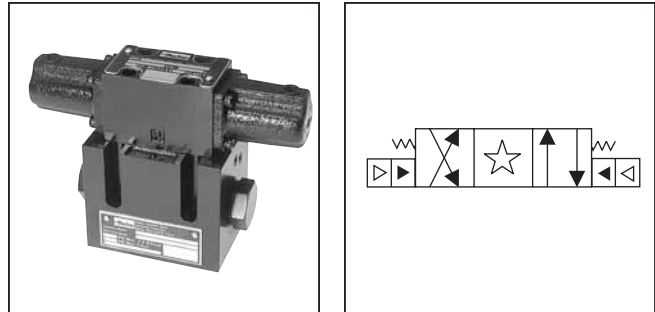

## Pressure Drop Chart

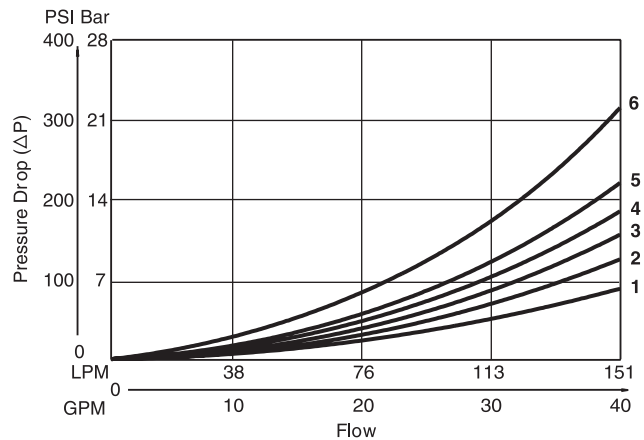

### VISCOSITY CORRECTION FACTOR

Viscosity (SSU)	75	150	200	250	300	350	400
% of ΔP (Approx.)	93	111	119	126	132	137	141

Curves were generated using 100 SSU hydraulic oil. For any other viscosity, pressure drop will change as per chart.

### D31VA Pressure Drop Reference Chart -- Curve Number

Spool No.	Shifted				Center Condition							
	P-A	P-B	B-T	A-T	(P-T)	(B-A)	(A-B)	(P-A)	(P-B)	(A-T)	(B-T)	
001	3	3	2	1	-	-	-	-	-	-	-	
002	3	3	1	1	3	3	3	4	4	1	1	
004	3	3	1	1	-	-	-	-	-	1	1	
009	3	3	1	1	6	-	-	-	-	-	-	
020	5	4	2	2	-	-	-	-	-	-	-	
030	4	3	1	1	-	-	-	-	-	-	-	

## D31VA Pressure Drop vs. Flow

The chart to the left provides the flow vs. pressure drop curve reference for the D31VA Series valves by spool type.

### Example:

Find the pressure drop at 76 LPM (20 GPM) for a D31VA with a number 001 spool. To the right of spool number 001, locate the number 3 in the P-A column, and 2 in the B-T column.

Using the top graph, locate curves 2 and 3 and read the pressure drop values. Total pressure drop through the valve is the sum of the two values.

**Ordering Information**

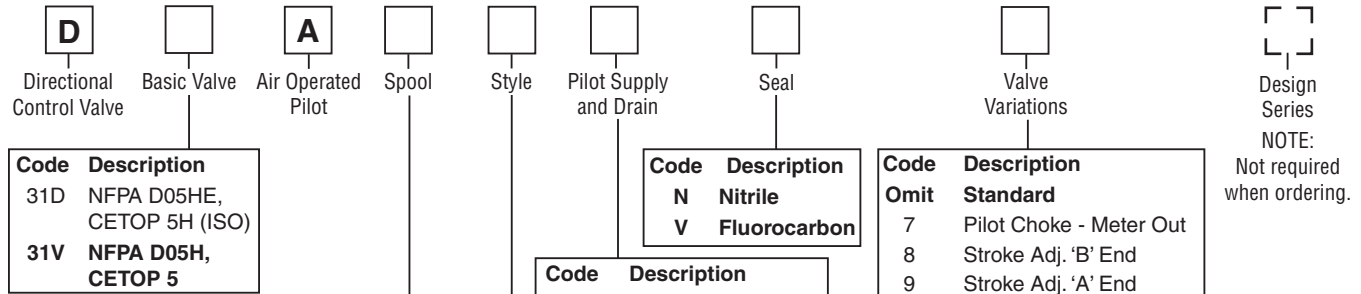

Code	Description
31D	NFPA D05HE, CETOP 5H (ISO)
<b>31V</b>	<b>NFPA D05H, CETOP 5</b>

Code	Description
<b>N</b>	<b>Nitrile</b>
<b>V</b>	<b>Fluorocarbon</b>

Code	Description
Omit	<b>Standard</b>
7	Pilot Choke - Meter Out
8	Stroke Adj. 'B' End
9	Stroke Adj. 'A' End
60	Pilot choke - Meter In
89	Stroke Adj. 'A' & 'B' Ends
90	1/4 BSPP Threads

Code	Description
<b>1</b>	<b>Int. pilot/Ext. drain</b>
<b>2</b>	<b>Ext. pilot/Ext. drain</b>
<b>4#</b>	<b>Int. pilot/Int. drain</b>
<b>5</b>	<b>Ext. pilot/Int. drain</b>

# Not available with 002, 008 & 009 spools.

Valve schematic symbols are per NFPA/ANSI standards, providing flow P to A when energizing operator A. Note operators reverse sides for #008 and #009 spools. See installation information for details.

Code	Symbol
001	
002	
004	
008†	
009*	
020†	
030*	

† 008 and 020 spools have closed crossover.  
 \* 009 and 030 spools have open crossover.

Code	Description	Symbol
<b>B†</b>	<b>Single operator, 2 position, spring offset. P to A and B to T in offset position.</b>	
<b>C</b>	<b>Double operator, 3 position, spring centered.</b>	
<b>D†</b>	<b>Double operator, 2 position, detent.</b>	
<b>E</b>	Single operator, 2 position, spring centered. P to B and A to T when energized.	
<b>H†</b>	<b>Single operator, 2 position, spring offset. P to B and A to T in offset position.</b>	
<b>K</b>	Single operator, 2 position, spring centered. P to A and B to T when energized.	

† Only spools 020 and 030.  
 This condition varies with spool code.

**Valve Weight:**  
 Double Operator  
 5.7 kg (12.7 lbs.)  
**Standard Bolt Kit:**  
 BK98  
**Metric Bolt Kit:**  
 BKM98

**Bold: Designates Tier I products and options.**

**Non-Bold: Designates Tier II products and options. These products will have longer lead times.**

**Dimensions – Air Operated** Inch equivalents for millimeter dimensions are shown in (\*\*)

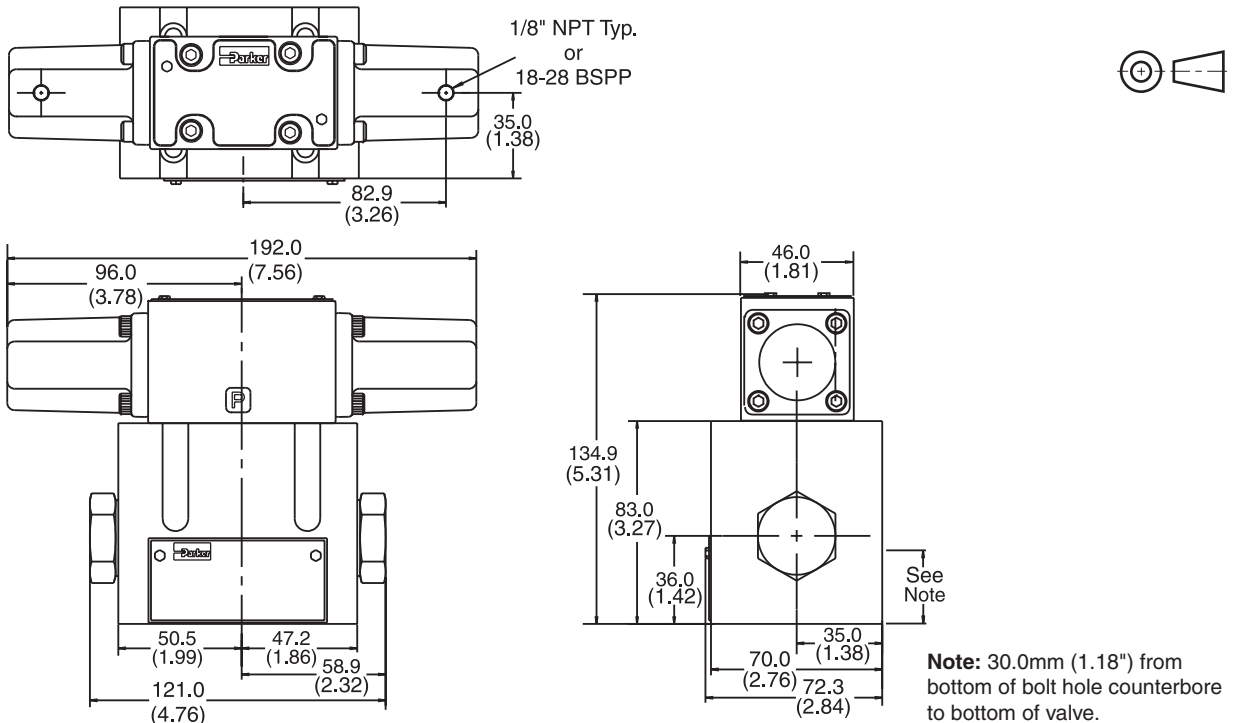

**Note:** 30.0mm (1.18") from bottom of bolt hole counterbore to bottom of valve.

## General Description

**A**

Series D31\*L directional control valves are 5-chamber, pilot operated, lever controlled valves. The valves are suitable for manifold or subplate mounting.

## Features

- **World design** – Available worldwide.
- **Mounting bolts below center line of spool** – Minimizes spool binding.
- **Five chamber style** – Eliminates pressure spikes in tubes, increasing valve life.
- **High pressure and flow ratings** – Increased performance options in a compact valve.

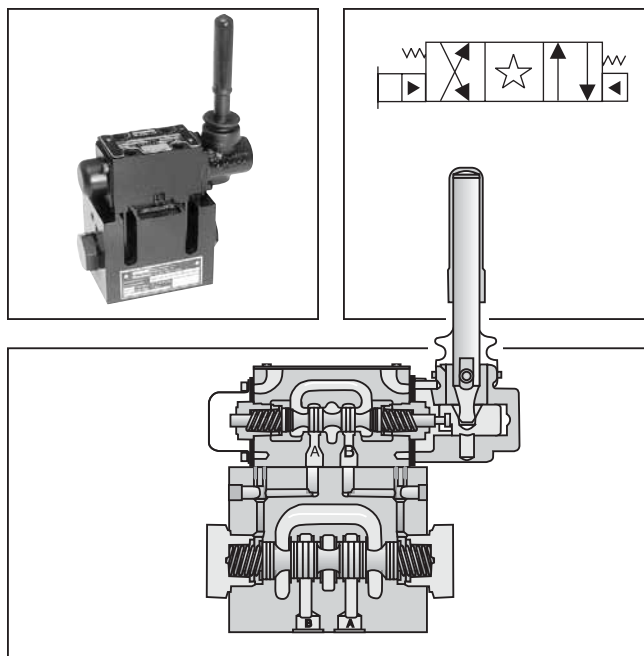

## Specifications

<b>Mounting Pattern</b>	NFPA D05H , CETOP 5 NFPA D05HE, CETOP 5H
<b>Max. Operating Pressure</b>	345 Bar (5000 PSI)
<b>Max. Tank Line Pressure</b>	Internal Drain Model: 34 Bar (500 PSI) External Drain Model: 207 Bar (3000 PSI)
<b>Maximum Flow</b>	See Switching Limit Charts
<b>Pilot Pressure</b>	Oil Min 6.9 Bar (100 PSI) Oil Max 345 Bar (5000 PSI)
<b>Max. Drain Pressure</b>	34 Bar (500 PSI)
<b>Response Time</b>	Varies with pilot line size and length, pilot pressure, pilot valve shift time & flow capacity (GPM)

## Pressure Drop Chart

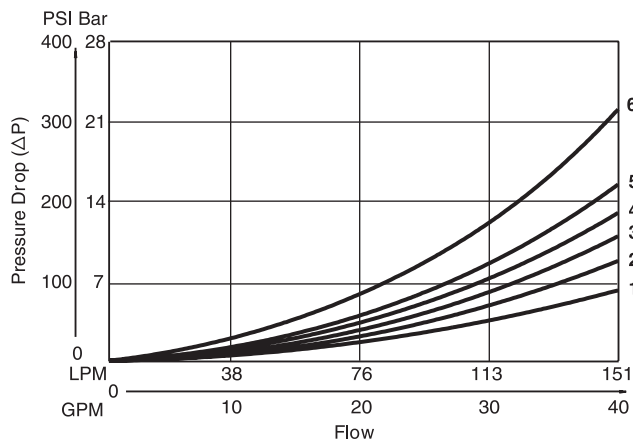

### VISCOSITY CORRECTION FACTOR

Viscosity (SSU)	75	150	200	250	300	350	400
% of ΔP (Approx.)	93	111	119	126	132	137	141

Curves were generated using 100 SSU hydraulic oil. For any other viscosity, pressure drop will change as per chart.

### D31VL Pressure Drop Reference Chart -- Curve Number

Spool No.	Shifted				Center Condition							
	P-A	P-B	B-T	A-T	(P-T)	(B-A)	(A-B)	(P-A)	(P-B)	(A-T)	(B-T)	
001	3	3	2	1	-	-	-	-	-	-	-	
002	3	3	1	1	3	3	3	4	4	1	1	
004	3	3	1	1	-	-	-	-	-	1	1	
009	3	3	1	1	6	-	-	-	-	-	-	
020	5	4	2	2	-	-	-	-	-	-	-	
030	4	3	1	1	-	-	-	-	-	-	-	

## D31VL Pressure Drop vs. Flow

The chart to the left provides the flow vs. pressure drop curve reference for the D31VL Series valves by spool type.

### Example:

Find the pressure drop at 76 LPM (20 GPM) for a D31VL with a number 001 spool. To the right of spool number 001, locate the number 3 in the P-A column, and 2 in the B-T column.

Using the top graph, locate curves 2 and 3 and read the pressure drop values. Total pressure drop through the valve is the sum of the two values.



**Ordering Information**

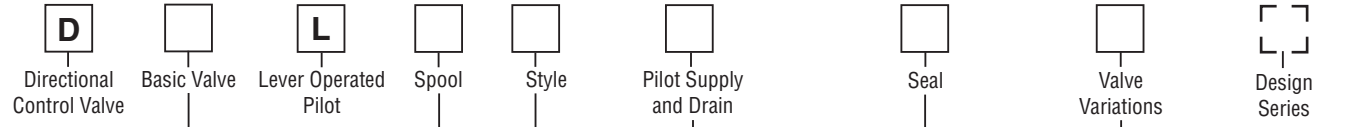

Code	Description
31D	NFPA D05HE, CETOP 5H (ISO)
31V	NFPA D05H, CETOP 5

Valve schematic symbols are per NFPA/ANSI standards, providing flow P to A when energizing operator A. Note operators reverse sides for #008 and #009 spools. See installation information for details.

Code	Symbol
001	
002	
004	
008**	
009*	
020**	
030*	

\* 009 and 030 spools have open crossover.  
 \*\* 008 and 020 spools have closed crossover.

Code	Description
1	Int. pilot/Ext. drain
2	Ext. pilot/Ext. drain
4#	Int. pilot/Int. drain
5	Ext. pilot/Int. drain

# Not available with 002, 008 & 009 spools.

Code	Description
N	Nitrile
V	Fluorocarbon

Code	Description
Omit	Standard
7	Pilot choke – meter out
8	Stroke adj. 'B' End
9	Stroke adj. 'A' End
60	Pilot choke – meter in
89	Stroke adj. 'A' & 'B' Ends

NOTE: Not required when ordering.

Code	Description	Symbol
B†	Sgl. operator, 2 position, spring offset. P to A and B to T in offset position.	
C	Dbl. operator, 3 position, spring centered.	
D†	Dbl. operator, 2 position, detent.	
E	Sgl. operator, 2 position, spring centered. P to B and A to T in shifted position.	
H†	Sgl. operator, 2 position, spring offset. P to B and A to T in offset position.	
K	Sgl. operator, 2 position. Spring centered. P to A and B to T in shifted position.	

† Only spools 020 and 030.

This condition varies with spool code.

**Valve Weight:** 5.4 kg (12.0 lbs.)  
**Standard Bolt Kit:** BK98  
**Metric Bolt Kit:** BKM98

**Bold: Designates Tier I products and options.**

**Non-Bold: Designates Tier II products and options. These products will have longer lead times.**

**Dimensions – Lever Operated** Inch equivalents for millimeter dimensions are shown in (\*\*)

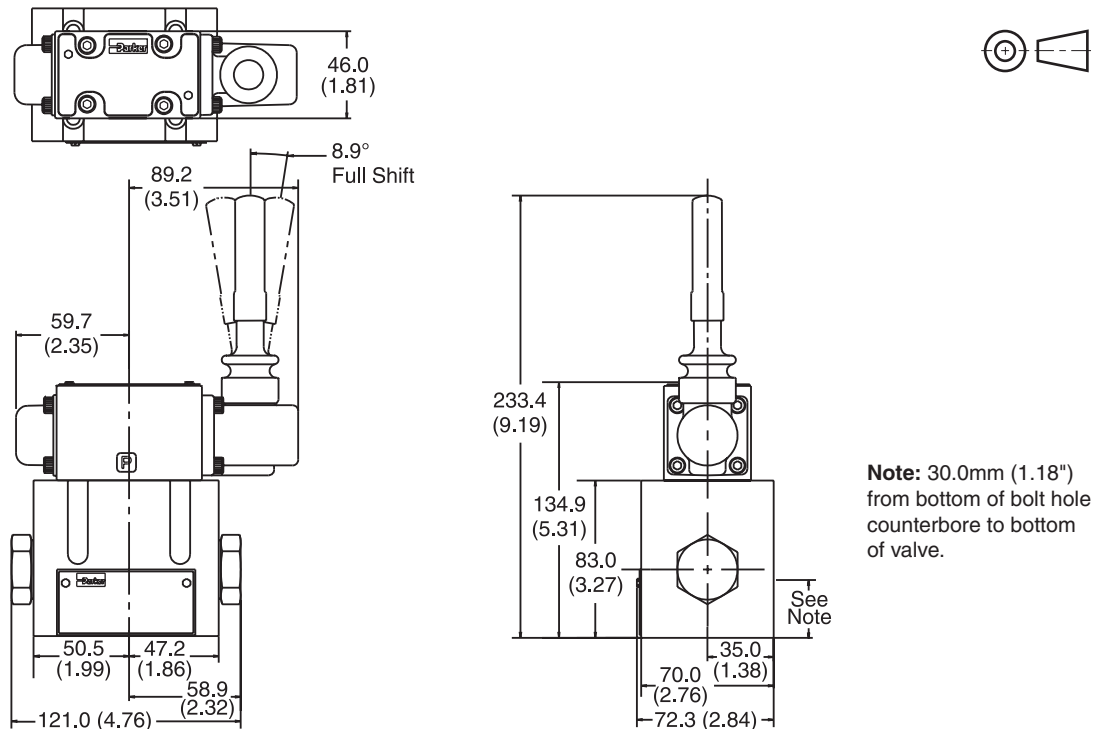

**Note:** 30.0mm (1.18") from bottom of bolt hole counterbore to bottom of valve.

## General Description

**A**

Series D3\*P directional control valves are 5-chamber, oil pilot operated valves. The valves are suitable for manifold or subplate mounting.

## Features

- **World design** – Available worldwide.
- **Mounting bolts below center line of spool** – Minimizes spool binding.
- **High pressure and flow ratings** – Increased performance options in a compact valve.

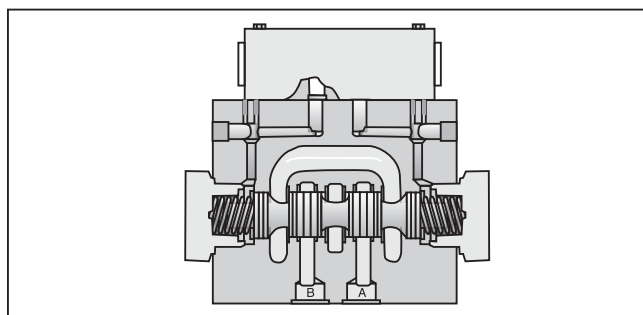
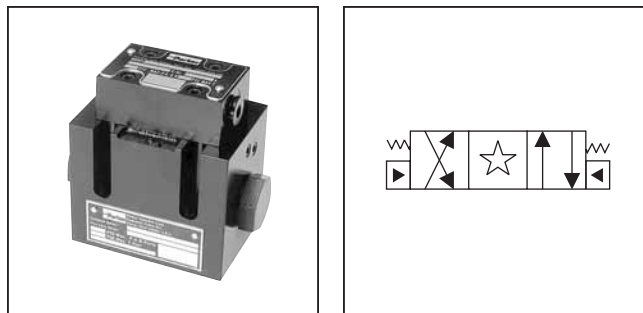

## Specifications

<b>Mounting Pattern</b>	NFPA D05H , CETOP 5 NFPA D05HE, CETOP 5H
<b>Max. Operating Pressure</b>	345 Bar (5000 PSI)
<b>Max. Tank Line Pressure</b>	207 Bar (3000 PSI)
<b>Pilot Pressure</b>	Oil Min: 6.9 Bar (100 PSI) Oil Max: 345 Bar (5000 PSI)
<b>Response Time</b>	Varies with pilot line size and length, pilot pressure, pilot valve shift time & flow capacity (GPM)

## Pressure Drop Chart

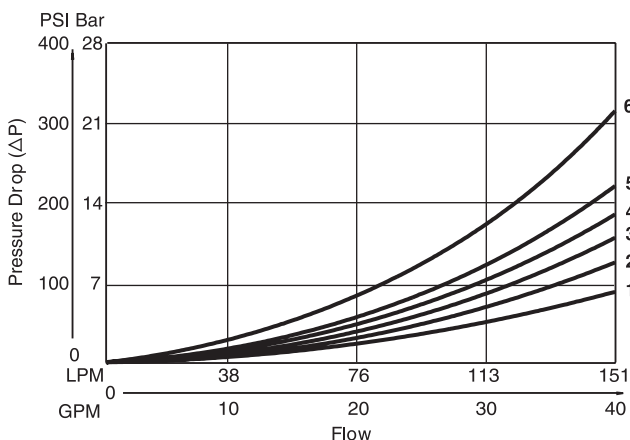

D3P Pressure Drop Reference Chart -- Curve Number											
Spool No.	Shifted				Center Condition						
	P-A	P-B	B-T	A-T	(P-T)	(B-A)	(A-B)	(P-A)	(P-B)	(A-T)	(B-T)
1	3	3	2	1	-	-	-	-	-	-	-
2	3	3	1	1	3	3	3	4	4	1	1
4	3	3	1	1	-	-	-	-	-	1	1
9	3	3	1	1	6	-	-	-	-	-	-
20	5	4	2	2	-	-	-	-	-	-	-
30	4	3	1	1	-	-	-	-	-	-	-

VISCOSITY CORRECTION FACTOR							
Viscosity (SSU)	75	150	200	250	300	350	400
% of ΔP (Approx.)	93	111	119	126	132	137	141

Curves were generated using 100 SSU hydraulic oil. For any other viscosity, pressure drop will change as per chart.

## D3P Pressure Drop vs. Flow

The chart to the left provides the flow vs. pressure drop curve reference for the D3P Series valves by spool type.

### Example:

Find the pressure drop at 76 LPM (20 GPM) for a D3P with a number 1 spool. To the right of spool number 1, locate the number 3 in the P-A column, and 2 in the B-T column.

Using the top graph, locate curves 2 and 3 and read the pressure drop values. Total pressure drop through the valve is the sum of the two values.



**Ordering Information**

<div style="border: 1px solid black; width: 20px; height: 20px; margin: 0 auto; display: flex; align-items: center; justify-content: center; font-weight: bold;">D</div> <p>Directional Control Valve</p>	<div style="border: 1px solid black; width: 20px; height: 20px; margin: 0 auto; display: flex; align-items: center; justify-content: center;"> </div> <p>Basic Valve</p>	<div style="border: 1px solid black; width: 20px; height: 20px; margin: 0 auto; display: flex; align-items: center; justify-content: center; font-weight: bold;">P</div> <p>Hydraulic Pilot</p>	<div style="border: 1px solid black; width: 20px; height: 20px; margin: 0 auto; display: flex; align-items: center; justify-content: center;"> </div> <p>Spool</p>	<div style="border: 1px solid black; width: 20px; height: 20px; margin: 0 auto; display: flex; align-items: center; justify-content: center;"> </div> <p>Style</p>	<div style="border: 1px solid black; width: 20px; height: 20px; margin: 0 auto; display: flex; align-items: center; justify-content: center;"> </div> <p>Pilot Supply and Drain</p>	<div style="border: 1px solid black; width: 20px; height: 20px; margin: 0 auto; display: flex; align-items: center; justify-content: center;"> </div> <p>Seal</p>	<div style="border: 1px solid black; width: 20px; height: 20px; margin: 0 auto; display: flex; align-items: center; justify-content: center;"> </div> <p>Valve Variations</p>	<div style="border: 1px dashed black; width: 20px; height: 20px; margin: 0 auto; display: flex; align-items: center; justify-content: center;"> </div> <p>Design Series</p> <p>NOTE: Not required when ordering.</p>
---	--	---	--	--	---	---	---	--

Code	Description	Code	Symbol
3D	NFPA D05HE, CETOP 5H	1	
3	NFPA D05H, CETOP 5	2	
		4	
		8**	
		9*	
		20**	
		30*	

Code	Description	Code	Description
N	Nitrile	7	Pilot Choke – Meter Out
V	Fluorocarbon	8	Stroke Adj. 'B' End
		9	Stroke Adj. 'A' End
		60	Pilot Choke – Meter In
		89	Stroke Adj. 'A' & 'B' Ends

Code	Description	Code	Description
2	Ext. pilot/Ext. drain	B†	Single operator, 2 position, spring offset. P to A and B to T in offset position.
5#	Ext. pilot/Int. drain	C	Double operator, 3 position, spring centered.
		H†	Single operator, 2 position, spring offset. P to B and A to T in offset position.

# Available on "B" and "H" styles only.

\* 9 and 30 spools have open crossover.  
 \*\* 8 and 20 spools have closed crossover.

**Valve Weight:**

Single Operator 1.4 kg (3.0 lbs.)  
 Double Operator 1.6 kg (3.5 lbs.)

**Standard Bolt Kit:** BK98

**Metric Bolt Kit:** BKM98

**Seal Kit:**

Nitrile SKD3P  
 Fluorocarbon SKD3PV

Code	Description	Symbol
B†	Single operator, 2 position, spring offset. P to A and B to T in offset position.	
C	Double operator, 3 position, spring centered.	
H†	Single operator, 2 position, spring offset. P to B and A to T in offset position.	

† Only spools 20 and 30.

This condition varies with spool code.

Valve schematic symbols are per NFPA/ANSI standards, providing flow P to A when energizing operator X. Note operators reverse sides for #8 and #9 spool. See installation information for details.

**Bold: Designates Tier I products and options.**

**Non-Bold: Designates Tier II products and options. These products will have longer lead times.**

**Dimensions – Oil Operated**

Inch equivalents for millimeter dimensions are shown in (\*\*)

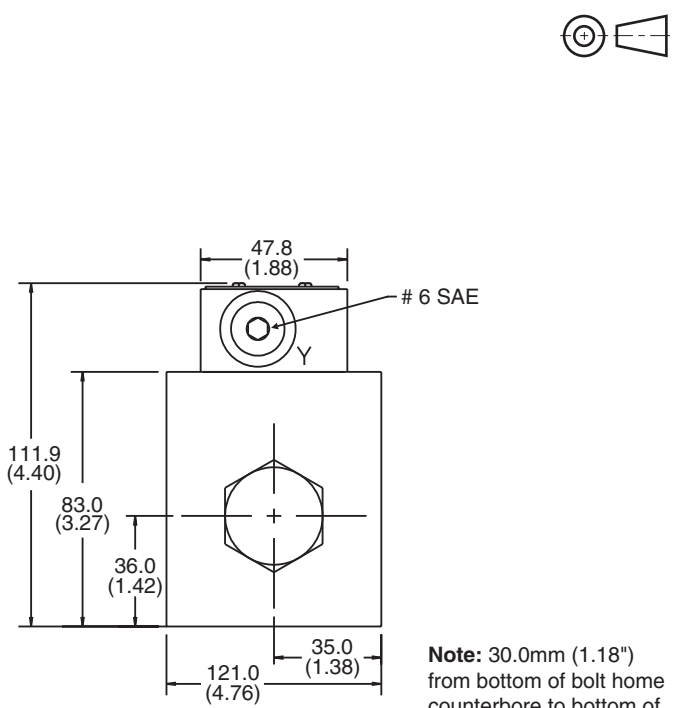
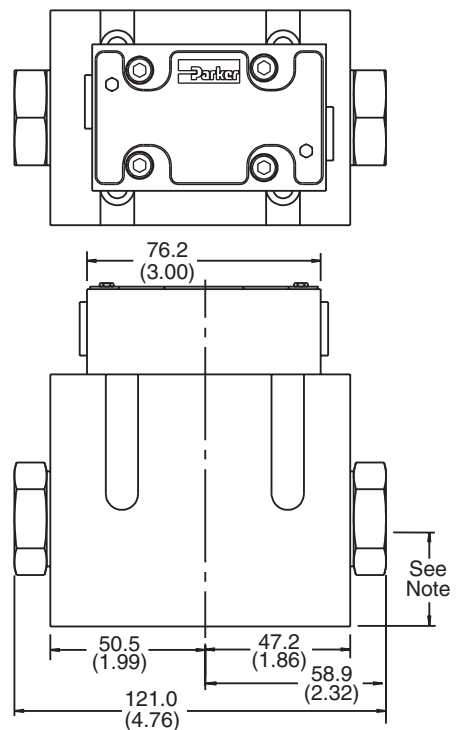

**Note:** 30.0mm (1.18") from bottom of bolt home counterbore to bottom of valve.

D31.indd, dd





FOR MAXIMUM VALVE RELIABILITY, ADHERE TO THE FOLLOWING INSTALLATION INFORMATION.

The following is important installation information which applies to all directional control valves described in this catalog.

**Mounting Position**

- Detent – Horizontal
- Spring Offset – Unrestricted
- Spring Centered – Unrestricted

**Fluid Recommendations**

Premium quality hydraulic oil with a viscosity range between 32-54 cst. (150-250 SSU) At 38°C (100°F) is recommended. The absolute operating viscosity range is from 16-220 cst. (80-1000 SSU). Oil should have maximum anti-wear properties and rust and oxidation treatment.

**Fluids and Seals**

Valves using synthetic, fire-resistant fluids require special seals. When phosphate esters or its blends are used, FLUOROCARBON seals are required. Water-glycol, water-in-oil emulsions and petroleum oil may be used with STANDARD seals.

**Filtration**

For maximum valve and system component life, the system should be protected from contamination at a level not to exceed 125 particles greater than 10 microns per milliliter of fluid (SAE class 4/ISO 16/13).

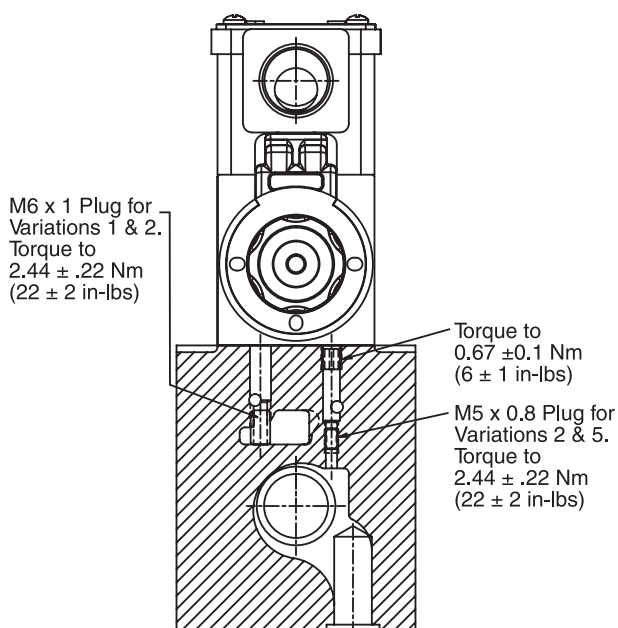

**Silting**

Silting can cause any sliding spool valve to stick and not spring return if held under pressure for long periods of time. The valve should be cycled periodically to prevent sticking.

**Special Installations**

Consult your Parker representative for any application requiring the following:

- Pressure above rating.
- Fluid other than those specified.
- Oil temperature above 71.1°C (160°F).
- Flow path other than normal.

**Mounting Patterns**

Series	NFPA	Size
D31V*, D3P	D05H, CETOP 5	3/8"
D31D*, D3DP, D31NW	D05HE, CETOP 5H	3/8"

**Torque Specifications**

The recommended torque values for the bolts which mount the valve to the manifold or subplate are as follows: 16.3 Nm (12 ft-lb).

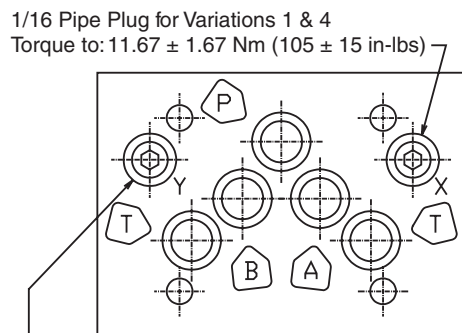

1/16 Pipe Plug for Variations 4 & 5  
Torque to: 11.67 ± 1.67 Nm (105 ± 15 in-lbs)

**NFPA D05HE, CETOP 5H Pattern D31DW**

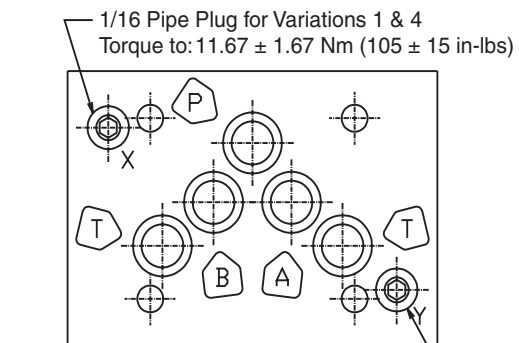

1/16 Pipe Plug for Variations 4 & 5  
Torque to: 11.67 ± 1.67 Nm (105 ± 15 in-lbs)

**NFPA D05H, CETOP 5 Pattern D31VW**



**SERIES D31\*W, D31\*A, D31\*L  
 PILOT OPERATED,  
 DIRECTIONAL CONTROL VALVES**

**Tank and Drain Line Surges**

If several valves are piped with a common tank or drain line, flow surges in the line may cause an unexpected spool shift. No spring style valves are most susceptible to this. Separate tank and drain lines should be piped in installations where line surges are expected.

**Electrical Failure or  
 Loss of Pilot Pressure (D31\*A)**

Should electric power fail or loss of pilot pressure occur, spring offset and spring centered valves will shift to the spring held position. Detented valves will stay in the last position held before power failure. If main flow does not fail or stop at the same time power fails, machine actuators may continue to function in an undesirable manner or sequence.

**Electrical Characteristics  
 (Detented Spool)**

Only a momentary energizing of the solenoid is necessary to shift and hold a detented spool. Minimum duration of the signal is 0.1 seconds for DC voltages. For AC voltages the response time is 0.06 seconds. Spool position will be held provided the spool centerline is in a horizontal plane, and no shock or vibration is present to displace the spool.

**Pilot/Drain Characteristics**

**Pilot Pressure:** 6.9 to 345 Bar (100 to 5000 PSI)

**External:** An oil source sufficient to maintain minimum pilot pressure must be connected to the “X” port of the main body. When using the external pilot variation, an M5 x 0.8 x 6mm long set screw must be present in the

main body pilot passage. (For details see Dimension pages.) This plug will be furnished in valves ordered with pilot code 2 or 5.

**Internal:** Flow is internally ported from the pressure port of the main valve body to the “P” port of the pilot valve. The pressure developed at the “P” port of the pilot valve must be 100 PSI (6.9 Bar) minimum at all times.

If the valve center condition allows flow from pressure to tank, 100 PSI (6.9 Bar) back pressure must be developed in the tank line to ensure sufficient pilot force at “P”. The “X” port in subplate must be plugged when using internal pilot variation (1/16 NPT).

**Pilot Valve Drain:**

Maximum pressure 102 Bar (1500 PSI), 207 Bar (3000 PSI) optional.

**External:** When using an external drain, an M6 x 1 x 10mm long set screw must be present in the main body drain passage. (For details see Dimension pages.) This plug will be furnished in valves ordered with drain code 1 or 2.

Drain flow from the pilot valve is at the “Y” port of the main body and must be piped directly to tank. Maximum drain line pressure is 102 Bar (1500 PSI), 207 Bar (3000 PSI) optional. Any drain line back pressure is additive to the pilot pressure requirement.

**Internal:** Drain flow from the pilot valve is internally connected to the main valve tank port. Tank and drain pressure are then identical so tank line pressure should not exceed 102 Bar (1500 PSI), 207 Bar (3000 PSI) optional. Any tank line back pressure is also additive to the pilot pressure requirement. If flow surges (a cause of pressure surges) are anticipated in the tank line, an external drain variation is recommended. The “Y” port in subplate must be plugged when using internal drain variations.

**D31\*W, D31\*A, D31\*L Flow Paths**

Style Code	Description	No Solenoid/Operator Energized	Solenoid/Operator A Energized	Solenoid/Operator B Energized
B	Spring Offset	P→A and B→T	—	P→B and A→T
C	Spring Centered	Centered	P→A and B→T	P→B and A→T
D	Detented	Last Position Held	P→A and B→T	P→B and A→T
E	Spring Centered	Centered	—	P→B and A→T
F†	Spring Offset, Shift to Center	P→A and B→T	—	Centered
H	Spring Offset	P→B and A→T	P→A and B→T	—
K	Spring Centered	Centered	P→A and B→T	—
M†	Spring Offset, Shift to Center	P→B and A→T	Centered	—

† D31\*W only.

D31.indd, dd



**A**

**SERIES D3P, D3DP PILOT OPERATED  
 DIRECTIONAL CONTROL VALVES**

**Tank and Drain Line Surges**

If several valves are piped with a common tank or drain line, flow surges in the line may cause an unexpected spool shift. Separate tank and drain lines should be piped in installations where line surges are expected.

**Loss of Pilot Pressure**

Should oil pilot pressure fail, spring offset and spring centered valves will shift to the spring held position. Detented valves will stay in the last position held before power failure. If main flow does not fail or stop at the same time power fails, machine actuators may continue to function in an undesirable manner or sequence.

**Mounting Pattern**

D3P valves may be mounted on a standard D05 pattern subplate or manifold only if the “X” and “Y” ports are externally connected to the pilot block on top of the main body. All other mounting styles require a D05H or D05HE pattern which incorporates ports for the “X” and “Y” pilot and drain passages. Location of these ports can be found on the Recommended Mounting Surface pages in this section.

**Pilot Drain Characteristics**

Pilot Pressure: 6.9 to 345 Bar (100 to 5000 PSI)

Direct pilot operated valves use the “X” and “Y” ports to supply pilot oil directly to the ends of the spool, providing spool shifting force. A block mounted on top of the valve body is internally cored to make the necessary connections. Thus when “X” is pressurized, “Y” is used as a drain; and when “Y” is pressurized, “X” becomes the drain.

Any back pressure in these lines when they are being used as a drain is additive to the pilot pressure requirement.

**Internal Drain:** On spring offset models, only the “X” port is pressurized, as the spring returns the spool to its at rest position. On these models, “Y” may be internally drained through the main tank passage in the valve.

**D3P Flow Path/Pilot Pressure**

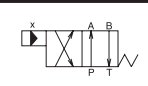
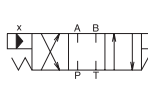
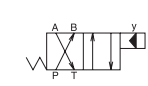
Style Code	Description	“X” & “Y” De-Pressurized	“X” Port Pressurized	“Y” Port Pressurized	Special Notes	Recommended Control Valve For Pilot Oil
B	Two Position Spring Offset	P→A, B→T	P→A, B→T	P→B, A→T	“X” Port may be pressurized to assist spring in returning spool to offset position (ext. only)	
C	Three Position Spring Centered	Center	P→A, B→T	P→B, A→T	Flow paths will be reversed on valves with tandem center (8) spools	
H	Two-Position Spring Offset	P→B, A→T	P→A, B→T	P→B, A→T	“Y” Port may be pressurized to assist spring in returning spool to offset position	

**Series D31VW, D31VA, D31VL, D3P**  
**Subplate Mounting**  
**NFPA D05H, CETOP 5**



**Recommended Mounting Surface**

Surface must be flat within .102 mm (0.0004 inch) T.I.R and smooth within 812.8 micro-meters (32 micro-inch). Torque bolts to 16.3 Nm (12 ft-lbs).

**Mounting Position**

Valve Type	Mounting Position
Detent (Solenoid)	Horizontal
Spring Offset	Unrestricted
Spring Centered	Unrestricted

***For maximum valve reliability, adhere to the following installation information.***

**Mounting Pattern — NFPA D05H, CETOP 5**

Inch equivalents for millimeter dimensions are shown in (\*\*)

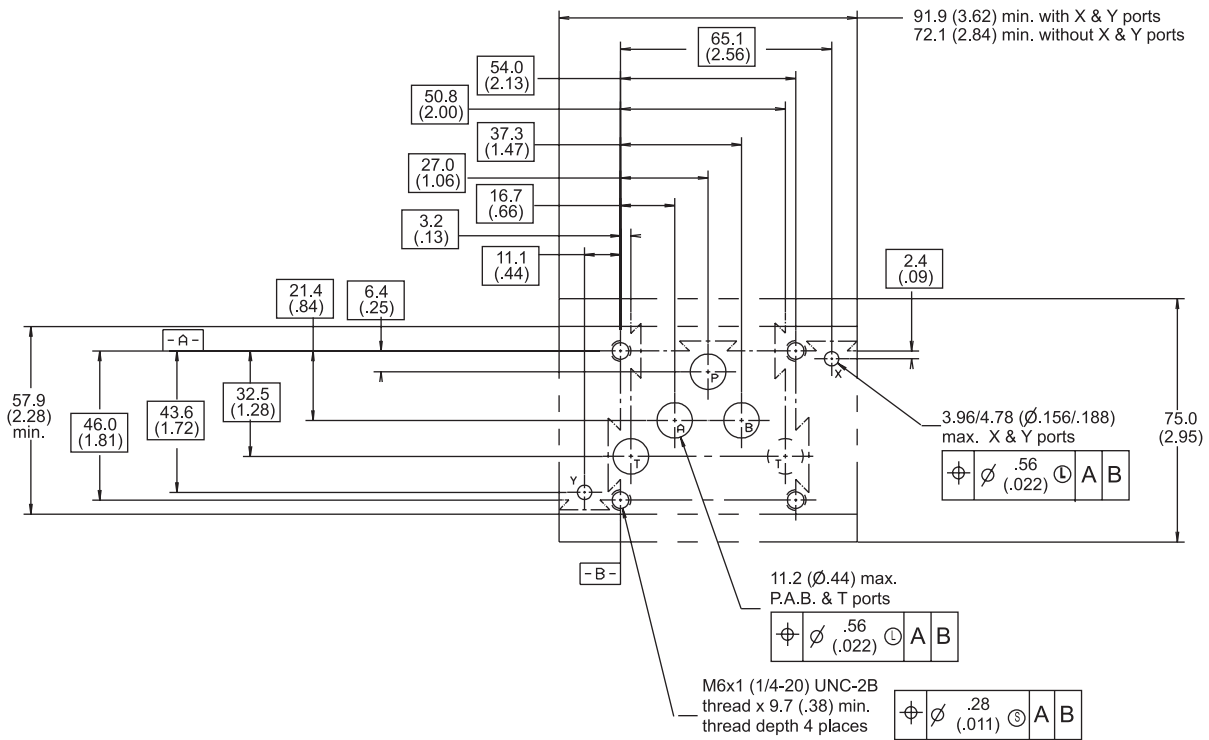

**Series D31DW, D31DA, D31DL, D3DP, D31NW**  
**Subplate Mounting**  
**NFPA D05HE, CETOP 5H**

**A**

**Recommended Mounting Surface**

Surface must be flat within .102 mm (0.0004 inch) T.I.R. and smooth within 812.8 micro-meters (32 micro-inch). Torque bolts to 16.3 Nm (12 ft-lbs).

**Mounting Position**

Valve Type	Mounting Position
Detent (Solenoid)	Horizontal
Spring Offset	Unrestricted
Spring Centered	Unrestricted

***For maximum valve reliability, adhere to the following installation information.***

**Mounting Pattern — NFPA D05HE, CETOP 5H**

Inch equivalents for millimeter dimensions are shown in (\*\*)

